

# FT Flexitest™ Switches Type FT-1, FT-1F, FT-1X & FT-14

Descriptive Bulletin 41-077

Effective: July, 2006

Supersedes DB 41-077, dated April 2005



*Figure 1. FT Flexitest Switch Products*

## Application

ABB Flexitest Switches, Types FT-1 (10 pole, rear connected), FT-1F (10 pole, front connected), FT-1X (10 pole, extended terminals, rear connected), FT-14 (14 pole, rear connected), and associated Test Plugs provide a safe, simple, fast and reliable method to isolate and service installed equipment.

**ABB**

## Advantages

FT test switches provide a safe, reliable, and cost-effective means to wire the output of relays, meters, and other associated equipment to external devices for in-service testing. FT test switches have been an industry standard for years.

- FT-1** The standard 10 pole, rear connected test switch.
- FT-1F** The surface mount switch allows the user to make the same connections as with FT-1 but on the front of the switch.
- FT-1X** The extended length test switch brings the rear terminal connections to the same depth as most panel mounted protective relays and equipment.
- FT-14** The FT-14 provides the same features and reliability as FT-1 but with a maximum of 14 individual poles. Although supplying 40% more capacity than the FT-1, the FT-14 only requires 18% more space.

**Safe and Convenient** All measurements and tests can be performed at the front of the switchboard without taking any devices out of service.

Flexitest Switches and Test Plugs have all the features necessary for applications involving the measurement of individual currents and voltages to facilitate testing of substation instrumentation and protection devices.

The make-before-break current short circuit feature allows test personnel to quickly and safely isolate equipment from current transformer (CT) circuits.

Voltage measurements can also be made directly on FT Switches without disturbing existing connections. There is a test clip located on the top of each pole that allows connection with standard spring clip test leads.

**Fast and Reliable** When Test Plugs are used, any number of circuits may be tested in rapid succession. One plug properly connected can test all instruments or meters of a particular type.

**Maximum Flexibility** Test switches can be assembled in a variety of different arrangements, to match customer requirements.

Test Plugs used in conjunction with FT Switches enable easy measurement, calibration, verification and maintenance of relays, meters and instruments.

**Security** With the cover in place, a meter type lead seal can be placed through either of the cover studs of any FT Switch to prevent unauthorized access to the switch. As an additional feature, a clear cover is available that can also be installed and locked with the switchblades in the open or closed positions.

## Warranty

ALL ABB Substation Automation and Protection test switches and relays are backed by a 12-YEAR warranty. The quality of ABB products comes from years of experience and rigorous quality testing programs.



## Specifications

### Ratings

All Flexitest Switches are rated at 600 volts and 30 amps. They meet or exceed all requirements of ANSI/IEEE Standard C37.90 and are UL, CUL and CSA listed. Class 1E Switches meet IEEE C37.98, C37.105, 323-1983 and 344-1987 Standards.

### Mounting

The FT-1, FT-14 and FT-1X Switches are designed for semi-flush mounting on the front of switchboard panels, facilitating inspection and accessibility. The FT-1F is designed for surface mounting and can also be mounted on a unistrut with the use of a unistrut adapter plate. Refer to Figures 12 to 16 beginning on page 28 for the specific outline and drilling plan information of each switch.

### Weight Specifications

<i>Device Type</i>	<i>Net Lbs (kg)</i>	<i>Shipping Lbs (kg)</i>
<i>FT-1 and FT-1F</i>	<i>1.75 (0.79)</i>	<i>3 (1.4)</i>
<i>FT-1X</i>	<i>2.7 (1.25)</i>	<i>3.75 (1.7)</i>
<i>FT-14</i>	<i>3.25 (1.5)</i>	<i>3.25 (1.5)</i>
<i>Separate Source Test Plug (10 position)</i>	<i>1.5 (0.68)</i>	<i>3 (1.4)</i>
<i>In-Service Series Test Plug (10 position)</i>	<i>1.5 (0.68)</i>	<i>3 (1.4)</i>
<i>Individual Current Circuit Test Plug</i>	<i>0.1 (0.045)</i>	<i>1 (0.45)</i>

### Construction

The base of all Flexitest Switches is made of a molded polycarbonate material, which provides a tough, insulated enclosure. Barriers are molded into the base (front and rear) to separate the switch units from one another. The barriers provide insulation between poles, and also ample wiring space between terminals. The terminals of the FT-1X are extended 10 inches beyond the switch blades located on the front of the switch.

### Cover

All Flexitest Switch covers provide a tough insulated enclosure for the switch and are made from a durable polycarbonate material. Covers are fastened to the switches with thumbnuts on either end that can accept meter seals. The thumbnuts can be loosened / tightened by hand, or with a 1/4" nut driver. This is the same size nut driver used on hex head terminal screws of all Flexitest Switches.

FT-1, FT-1F, and FT-1X may be purchased with a black opaque cover or a clear cover, while FT-14 is available with a clear cover.

The clear cover affords the user the unique option of intentionally leaving switch handles in the open position and replacing the cover while maintaining the provision for a meter seal. This feature allows the user to service electrical equipment while still complying with OSHA tag and lockout procedures.

Clear covers can be ordered separately to retrofit any existing switch. Users will maintain the same ease of use and accessibility as with the black opaque cover. Lockable covers (in black or clear) are also available upon request.

**Poles**

FT-1, FT-1F and FT-1X switches are available in combinations of 1 to a maximum of 10 individual poles or switch units. FT-14 switches are available in combinations of 1 to a maximum of 14 poles or switch units. Each pole is identified by a letter (A to J or A to N) visible along the top of the base from left to right (front view).

Each individual pole is of a knife blade type. There are two different types of poles, Potential and Current. Potential poles (P) are configured as single, non-shorting knife blades for use in potential, trip, or control circuits. Current poles are typically configured in sets of two (C-C), for use with current circuits, and consist of a current test jack, a shorting spring, a shorting blade, and a non-shorting blade (see Figure 2). The positions of the short circuit springs are always visible from the front of the switch.

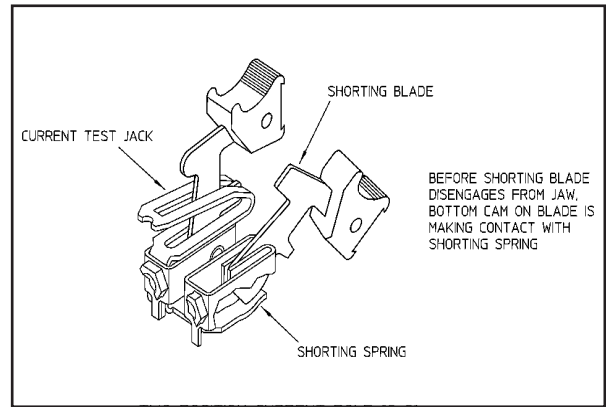

Figure 2. Blade assembly of 2 position pole "C-C" (rear view outside of base)

**Switch Handles**

Switch handles are made of a molded phenolic material. They are typically black for potential and current circuits, red for trip circuits. In addition to black and red, switch handles are also available in various other colors (green, yellow, blue, white, and orange). Each handle has a dovetail indentation that can hold a circuit identification label.

Knife blade switches can be operated independently, or ganged together with a horizontal interlocking bar, to suit testing needs. A hole runs through the middle of each switch handle to allow insertion of interlocking bars that can mechanically tie 2, 3, 4, 5, 6, 8, 10, or 14 switch handles together.

Interlocking Bars are sold separately. (See "Test Plug & Accessories – Ordering Information" on page 12).

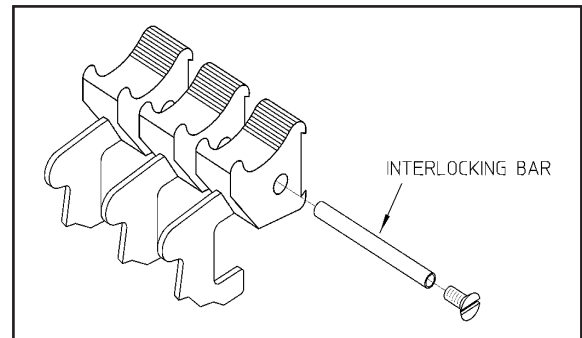

Figure 3. Switch handles with interlocking bar

**Terminals**

The connection terminals are located at the rear of the switch (except on FT-1F). Terminal numbers are marked for easy identification along the rear of the switch (1 to 20 or 1 to 28 on FT-14). Each pair of numbered terminals is associated with a matching pole designated by a letter on the front of the switch, see Figure 4.

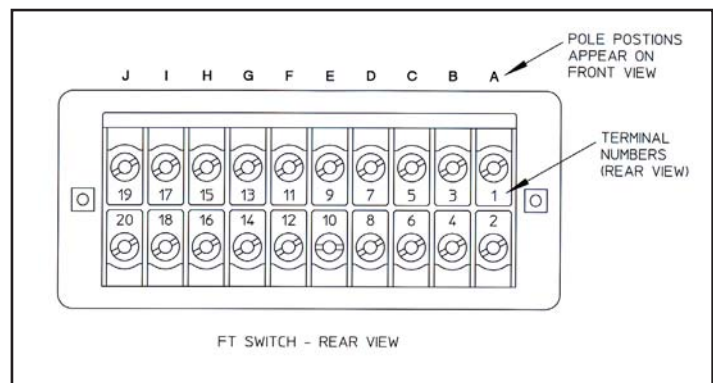

Figure 4. Terminal connections on FT-1 Switch, rear view

### Terminal Connections

All required terminal hardware is supplied with each FT Flexitest Switch. Screw terminals are provided with standard FT switch styles which require customer connections be made with a hex washer head screw, #8 thread size (0.164-32) with a 1/4" hex head. Stud and nut terminals are an optional feature where connections are made by means of two washers and a nut (see Figure 5). A special (5/16") nut driver can be purchased from ABB to connect to stud terminals, see "Test Plug & Accessories - Ordering Information" on page 12.

**Recommended maximum torque values for all FT-1 & FT-14 terminals is 16 in-lbs. Exceeding this torque may result in damage to terminal threads.**

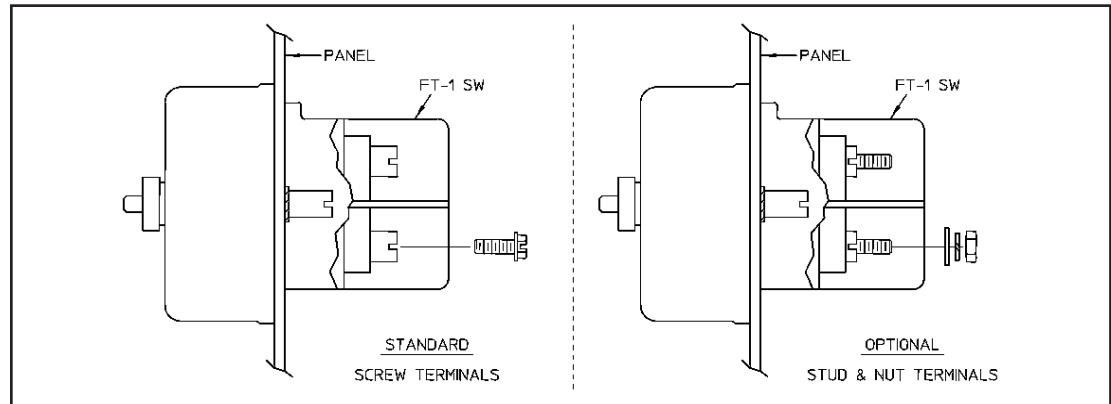

Figure 5. Standard and Optional Terminals



**Connections to ALL equipment should be made using standard and safe connection practices.**

**Even number terminals (bottom row) of FT switches should be connected to Voltage Transformers and Current Transformers, while odd number terminals (top row) should be connected to equipment that is to be isolated, such as meters and relays.**

**All Switch Arrangements should be checked for adequate current transformer shorting when applied to current transformer circuits.**

### FT Flexitest Switches - Ordering Information

#### FT-1 Ordering Information



Example Style Number

-- **1 2 9 A 5 0 1 G 0 1**

Standard Style

Style Prefix:

- None = Black cover, screw terminals.
- S = Black cover, stud & nut terminals.
- C = Clear cover, screw terminals.
- CS = Clear cover, stud & nut terminals.
- R = For FT-19R application, screw terminals.
- RS = For FT-19R application, stud & nut terminals.

#### FT-1F Ordering Information

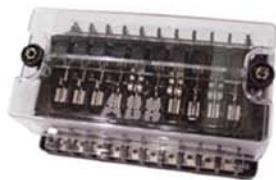

Example Style Number

-- **F 1 2 9 A 5 0 1 G 0 1**

Standard Style

Style Prefix:

- F = Black cover, screw terminals.
- SF = Black cover, stud & nut terminals.
- CF = Clear cover, screw terminals.
- CSF = Clear cover, stud & nut terminals.

#### FT-1X Ordering Information



Example Style Number

-- **1 2 9 A 5 0 1 G 0 1 X 1 0**

Standard Style

Extended Length:

Style Prefix:

- None = Black cover, screw terminals.
- S = Black cover, stud & nut terminals.
- C = Clear cover, screw terminals.
- CS = Clear cover, stud & nut terminals.
- R = For FT-19R application, screw terminals.
- RS = For FT-19R application, stud & nut terminals.

X10 = 10 inches

### FT-14 Ordering Information



Complete Smart Number	Flexitest Switch	Base Type	Depth	No. of Poles	Terminal Connections	No. of Potential Poles	Cover	Special Features	Code No.
FT4A14T14CN4001	FT	4	A	14	T	14	C	N	4001

**Base Type:** \_\_\_\_\_  
 4 = FT-14

**Depth:** \_\_\_\_\_  
 A = Standard depth (rear connected)

**No. of Poles:** \_\_\_\_\_  
 01-14 = Total number of poles used

**Terminals:** \_\_\_\_\_  
 T = Standard screw terminals  
 S = Stud & nut terminals

**No. of Potentials:** \_\_\_\_\_  
 01-14 = Total number of Potential poles used (see Description of Poles)

**Cover:** \_\_\_\_\_  
 C = Clear cover

**Special Features:** \_\_\_\_\_  
 N = None

**Code No:** \_\_\_\_\_  
 4001-4999 = Unique FT14 Code Number assigned by the factory

### Ordering Information

#### Flexitest Switches

FT-1, FT-1F and FT-1X switches are available in any combination of 1 to 10 poles and FT-14 is available in any combination up to 14 poles. Each different configuration of poles is assigned a unique part number or Style Number by the factory.

All FT switches are ordered by Style Number. The standard FT-1 Style Number defines a unique pole configuration. Adding a prefix and/or suffix to the standard Style Number allows the selection of options for FT-1 as well as the ability to create complete FT-1F and FT-1X Style Numbers (see Ordering Information on page 6). FT-14 Style Numbers are based on a smart part number system (see Ordering Information on page 7).

The FT-1 Selection Guide, (Table 1, pages 13-20) and the FT-14 Selection Guide (Table 2, pages 21 & 22) provide a comprehensive listing of existing Style Numbers.

#### “How-To” Ordering Examples

The ordering information in Tables 1 and 2 (FT-1 and FT-14 Switch Selection Guides) is organized by number of poles and also by number of potential and current poles. To look up a 10 pole FT-1 switch, go to the 10 pole section of Table 1 and select the desired potential and current pole positions then select the corresponding Style Number.

ex: 10 Poles (6 Potentials, 4 Currents) **P P P P P C-C-C-C** = Style Number 670B197G28

An FT-1 switch with black cover and screw terminals will be supplied when ordering the standard Style Number as listed in Table 1, ex: 129A501G01. An optional clear cover will be supplied instead of the black cover by using Style Number prefix "C," ex: C129A501G01. An FT-1X extended switch with clear cover will be supplied by using prefix "C" and suffix "X10", ex: C129A501G01X10.

Optional stud and nut terminals are available for all FT switches. Style Number prefix "S" is used for this option, ex: S129A501G01. For optional clear cover with stud and nut terminals use Style Number prefix "CS", ex: CS129A501G01.

For FT-1, FT-1F, FT-1X, and FT-14 switch requirements not matching an existing Style Number in Tables 1 & 2, select the Style Number that comes closest to the desired configuration and describe the new configuration as similar to the existing Style chosen.

Customers may also place an order by providing a complete Switch Arrangement definition. ex: **P X P C-C C-C C-C P**.

**Switch Arrangement**

Pole positions are identified from left to right on the front view of the switch by the letters "A" through "J" or "A" through "N". Individual pole designations are used to identify each pole according to its type or function. In order to develop a complete Switch Arrangement, pole designation should be listed sequentially from left to right to account for every pole position on the switch. Unused poles are identified by the letter X.

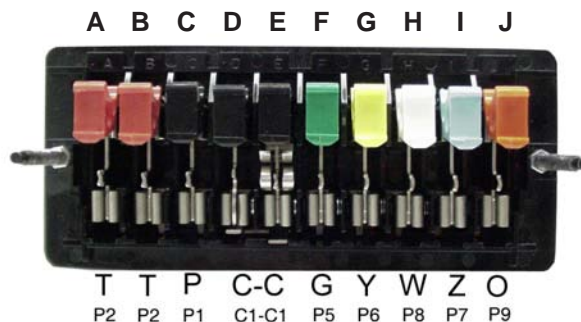

**Potential Poles**

P designates a Potential or control circuit with a black handle. Potential poles with other color handles are available by replacing the "P" with the appropriate designation per chart below.

Handle Color	Black	Red	Green	Yellow	Blue	White	Orange
Pole Designation	P	T	G	Y	Z	W	O
Alternate Designation *	P1	P2	P5	P6	P7	P8	P9

\* = Each potential pole can also be described with 2 characters, P indicates Potential and the second character is a numeric color code for the switch handle.

**Current Poles**

C designates a single Current circuit, non-shorting pole, with a current test jack and a black handle. Current poles with other color handles are available by replacing the "C" with the appropriate designation per chart below.















Handle Color	Black	Red	Green	Yellow	Blue	White	Orange
Pole Designation	C	R	5	6	7	8	9
Alternate Designation *	C1	C2	C5	C6	C7	C8	C9

\* = Each current pole can also be described with 2 characters, C indicates Current and the second character is a numeric color code for the switch handle.

Current poles typically span more than one pole position. Pole designations C-C, C-C-C, C-C-C-C and C-C-C-C-C indicate current shorting poles (make-before-break) with black handles. Note that any color handle may be selected for any current pole by using the appropriate pole designation, ex: 5-R or C-9-7 (alternately C5-C2 or C1-C9-C7).





For a complete listing of available Pole Designations and their definitions see page 9.

### Description of Poles - FT Flexitest Switches

Pole Type	Pole Designation		Handle Color	Description & Schematic Symbol
Potential	<b>P</b>	P1	Black	Potential, non-shorting blade. 
	<b>T</b>	P2	Red	
	<b>G</b>	P5	Green	
	<b>Y</b>	P6	Yellow	
	<b>Z</b>	P7	Blue	
	<b>W</b>	P8	White	
	<b>O</b>	P9	Orange	
	<b>L</b>	L1	Black ††	Potential, shorting blade. 
Current	<b>C</b>	C1	Black	Current, non-shorting, with test jack and blade. 
	<b>R</b>	C2	Red	
	<b>5</b>	C5	Green	
	<b>6</b>	C6	Yellow	
	<b>7</b>	C7	Blue	
	<b>8</b>	C8	White	
	<b>9</b>	C9	Orange	
	<b>D</b>	D0	None	Current test jack, no blade. 
Current Shorting †	<b>C-C</b>	C1-C1	Black ††	Current shorting (make-before-break), with test jack and blade. 
	<b>C-A</b>	C1-A1		Current shorting (make-before-break), with blade only. 
	<b>C-B</b>	C1-B0		Current shorting (make-before-break), with stud only. 
	<b>C-D</b>	C1-D0		Current shorting (make-before-break), with test jack only. 
	<b>C-E</b>	C1-E1		Current shorting (make-before-break), with shorting blade only. 
	<b>C-S</b>	C1-S0		Current shorting (make-before-break), with fixed shorting strap. 
Miscellaneous	<b>S</b>	S0	None	Fixed shorting strap. 
	<b>J</b>	J0	None	Current jaw, no blade. 
	<b>N</b>	N0	None	Terminal stud in blade location, no jaw. 
	<b>U</b>	U0	None	Stud and test clip in jaw location, no blade. 
	<b>X</b>	X0	None	Empty pole position. 

† = Current shorting poles are also available spanning up to 5 positions (ex: **C-C-C-C-C** or alternately C1-C1-C1-C1-C1).  
 †† = Every color handle is available. Substitute appropriate pole color designation in desired location (ex: current shorting poles with color handles: **5-5**, **5-2-C**, or alternately C5-C5, C5-C2-C1).

### Schematic Legend

Non-Shorting Blade	Shorting Blade	Current Test Jack	Shorting Spring
			

## Test Plugs

### In-Service Series Test Plug

The “In-Service” Series Test Plug with a maximum of 10 positions is designed to match the pole configurations of specific styles of FT Flexitest devices (either FT-1, FT-1F, FT-1X switches or FT case relays).

This Test Plug is typically used to connect devices measuring the currents and voltages being applied to the switchboard relays, meters and instruments without interrupting or short-circuiting the circuit. Only current test switches with a current jack must be opened before inserting the Series Test Plug. Connections to the test plug must be made before inserting the test plug into an FT switch or relay.



Figure 6. In-Service Series Test Plug

Not every switch or relay pole configuration is suitable to accept an In-Service Series Test Plug. For available Styles, see Table 1, page 13, “TEST PLUG” column.



**WARNING**

***When using an In-Service Series Test Plug for current measurements, connections from the Test Plug to the measuring instruments must be made before inserting the Test Plug in place.***

### Individual Current Circuit Test Plug

The Individual Current Circuit Test Plug allows in service current measurement with an ammeter. It can be inserted in the current test jack of FT Flexitest devices after opening the knife blade switch. This plug consists of two conducting strips separated by an insulating strip. The ammeter is connected to these strips by terminal screws and leads carried out through holes in the back of the insulated handle. (See Figures 7 and 8.)



Figure 7. Individual Current Circuit Test Plug

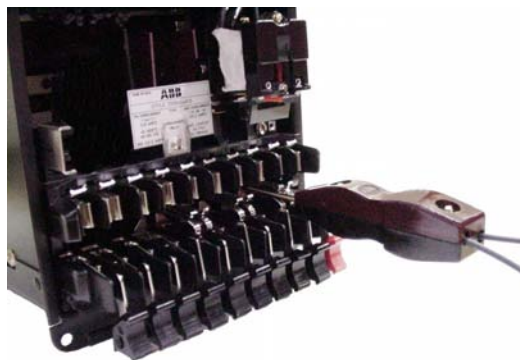

Figure 8. Individual Current Circuit Test Plug inserted in Flexitest Relay Case



**WARNING**

***Connections from the Individual Current Circuit Test Plug to the measuring instrument must be made before inserting the Test Plug in place.***

The test plug inserts into the current test jack with the red part of the handle facing up allowing the alignment nipple and tab to guide the connector into the test jack.

### Separate Source Test Plug

The 10 Position Separate Source Test Plug isolates the external connections from the relay or equipment under test. The test plug accepts all common size banana plugs, ring wire connectors, spade lugs and has a through hole for meter probe or wire connections.

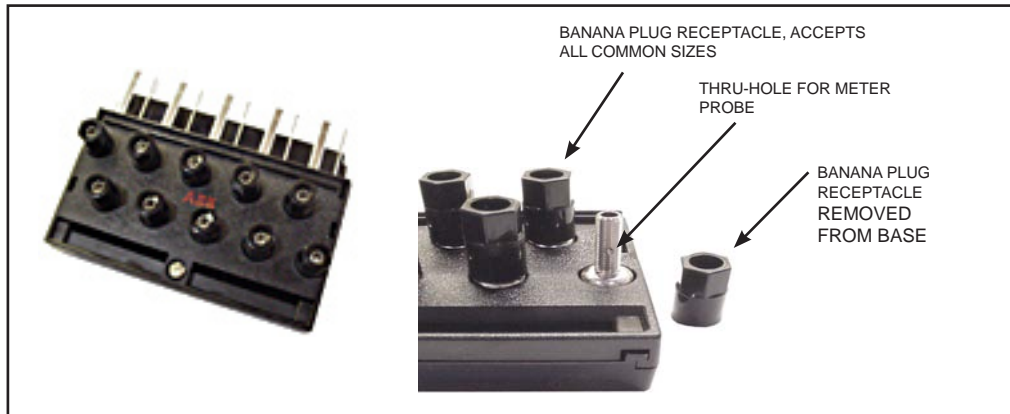

Figure 9. Separate Source Test Plug

This test plug provides quick circuit testing by fitting into the stationary contact jaws of any Flexitest Type FT Case or Switch. The L-shaped test blades assure quick, accurate alignment between the Test Plug and the stationary contact jaws. The blades connect the relay inputs and outputs to a set of binding banana posts on the top of the Test Plug. An insulated barrier along the bottom of the blades isolates the relay circuits from external connections. Test circuits can then be connected to these binding posts, which are staggered for easy accessibility.

Before inserting the Separate Source Test Plug into service, all switchblades must be placed in the full open position. In a Flexitest Type FT Case, the plug is inserted in the bottom switch jaw with the binding posts up and in the top test switch jaw with the binding posts down.



Figure 10. Separate Source Test Plug inserted in Flexitest Relay Case



**Provision is made only on current poles with shorting springs to automatically short-circuit current transformer circuits when the knife switches are opened prior to inserting the Test Plug.**

### FT Test Kit

The ABB FT test kit comes with a convenient carrying case to hold your hand held meter, test plugs, patch cords, test clips, and test probes in neat order. FT Test Kits can be ordered with your selected quantities of test plugs, patch cords, test clips, and test probes. Patch cords are highly durable and flexible. Contact your local ABB representative for a quotation.

To order the FT Test Kit with items shown shown here, use ordering number 9688A68G18. For more information see "Test Plugs & Accessories - Ordering Information" on page 12.



**Test Plugs & Accessories - Ordering Information**

Description		Style Number	Photo	
In-Service Series Test Plug (Order to match Flexitest FT relay case or FT-1 Switch arrangement)		See Table 1, p.13		
Individual Current Circuit Test Plug (leads not included)		7B4618G04		
Separate Source Test Plug (10 position)		1164046		
Separate Source Test Plug (14 position)		1355D32G04		
Complete FT Test Kit (Includes RED 12 Year Warranty Bag)		9688A68G18		
<b>Items in Test Kit 9688A68G18</b>		<b>Rated Voltage</b>		<b>Rated Current</b>
1 Red, 6 FT. safety patch cord with retractable sleeve (banana plug both ends)		600 VDC		32A
1 Black, 6 FT. safety patch cord with retractable sleeve (banana plug both ends )		600 VDC		32A
1 Red plug-on test probe		1000V		10A
1 Black plug-on test probe		1000V		10A
1 Red plug-on test clip (alligator type)		1000V		32A
1 Black plug-on test clip (alligator type)		1000V		32A
FT Separate Source Test Plug - 1164046		600V		30A
Individual Series Test Plug - 7B4618G04		600V	30A	
Clear Cover with Thumb Nuts		9676A32G01		
Black Cover with Thumb Nuts		128A973G01		
Nut Driver (For Stud & Nut Terminals only, Prefix "S")		877A821G01		
Interlocking Bars	2 Position	1270547		
	3 Position	1164048		
	4 Position	02C9834G03		
	5 Position	02C9834G04		
	6 Position	02C9834G06		
	8 Position	02C9834G07		
	10 Position	02C9834G05		
Unistrut Adapter Plate (for FT-1F)		9666A15H01		

Table 1 - FT-1 Switch Selection Guide

POTENTIAL	CURRENT											STYLE NO.	TEST PLUG
		A	B	C	D	E	F	G	H	I	J		
1	0	P	.	.	.	.	.	.	.	.	.	774B542G09	129A062G10
<b>2</b>													
Pole		A	B	C	D	E	F	G	H	I	J		
2	0	.	.	.	.	.	.	P	.	P	.	291B954G15	129A062G10
2	0	.	.	P	.	P	.	.	.	.	.	129A534G01	129A062G10
2	0	P	P	.	.	.	.	.	.	.	.	291B954G13	129A062G10
2	0	T	.	.	.	.	.	.	.	T	.	291B954G14	129A062G10
2	0	T	O	.	.	.	.	.	.	.	.	9688A46G01	129A062G10
2	0	T	T	.	.	.	.	.	.	.	.	291B954G16	129A062G10
2	0	Z	Z	.	.	.	.	.	.	.	.	9676A38G01	129A062G10
0	2	.	.	.	.	.	.	C-C	.	.	.	291B954G12	129A062G01
0	2	.	.	.	.	C-C	.	.	.	.	.	129A531G01	129A062G08
0	2	.	C-C	.	.	.	.	.	.	.	.	498A026G01	129A062G07
0	2	C-C	.	.	.	.	.	.	.	.	.	9689A74G01	129A062G07
<b>3</b>													
Pole		A	B	C	D	E	F	G	H	I	J		
3	0	.	.	.	.	.	.	P	P	P	.	716B871G11	129A062G10
3	0	.	.	P	P	P	.	.	.	.	.	716B871G09	129A062G10
3	0	.	.	T	T	T	.	.	.	.	.	9689A75G01	129A062G10
3	0	.	.	Z	Z	Z	.	.	.	.	.	9688A63G01	129A062G10
3	0	P	.	P	.	.	.	P	.	.	.	716B871G12	129A062G10
1	2	C-C	.	.	.	.	.	T	.	.	.	9663A78G01	<1>
0	3	.	.	C	C	C	.	.	.	.	.	716B871G10	<1>
<b>4</b>													
Pole		A	B	C	D	E	F	G	H	I	J		
4	0	.	.	T	P	T	P	.	.	.	.	9676A26G01	129A062G10
4	0	.	.	T	T	T	P	.	.	.	.	9676A27G01	129A062G10
4	0	.	P	P	P	P	.	.	.	.	.	129A524G01	129A062G10
4	0	.	T	.	T	.	T	.	T	.	.	291B956G31	129A062G10
4	0	.	T	T	T	T	.	.	.	.	.	1586C39G01	129A062G10
4	0	.	T	T	T	T	.	.	.	.	.	291B956G32	129A062G10
4	0	.	Z	Z	Z	Z	.	.	.	.	.	9689A80G01	129A062G10
4	0	.	P	.	P	.	P	.	P	.	.	9688A64G01	129A062G10
4	0	P	.	.	.	.	.	P	P	P	.	129A506G01	129A062G10
4	0	P	.	P	.	.	P	.	P	.	.	291B956G24	129A062G10
4	0	P	.	P	P	P	.	.	.	.	.	291B956G25	129A062G10
4	0	P	.	T	.	Y	.	Z	.	.	.	9647A17G01	129A062G10
4	0	P	P	.	.	.	.	P	P	.	.	129A538G01	129A062G10
4	0	P	P	P	.	.	.	P	.	.	.	498A022G01	129A062G10
4	0	P	P	P	.	.	.	T	.	.	.	9663A80G01	129A062G10
4	0	P	P	P	P	.	.	.	.	.	.	9672A73G01	129A062G10
4	0	T	.	.	.	.	.	P	P	T	.	763A166G01	129A062G10
4	0	T	.	.	.	.	.	T	T	T	.	498A012G01	129A062G10
4	0	T	.	T	.	.	.	T	.	T	.	862A584G01	129A062G10
4	0	T	T	T	.	.	.	.	.	T	.	1586C39G02	129A062G10

POTENTIAL	CURRENT											STYLE NO.	TEST PLUG
		A	B	C	D	E	F	G	H	I	J		
4	0	T	T	T	T	.	.	.	.	.	.	9688A79G01	129A062G10
3	1	P	P	C	.	.	.	.	.	P	.	291B956G26	<1>
3	1	P	P	P	S	.	.	.	.	.	.	9688A67G01	<1>
2	2	O	O	C-C	.	.	.	.	.	.	.	9688A25G01	<1>
2	2	P	.	.	.	.	.	C-C	P	.	.	129A507G01	129A062G01
2	2	P	P	.	.	.	.	C-C	.	.	.	291B956G18	129A062G01
2	2	P	P	C-C	.	.	.	.	.	.	.	291B956G30	<1>
2	2	T	.	.	.	.	.	C-C	P	.	.	9671A05G01	129A062G01
2	2	T	T	.	.	.	.	C-C	.	.	.	9676A36G01	129A062G01
2	2	W	W	.	.	.	.	C-C	.	.	.	9688A03G01	129A062G01
1	3	.	.	C	C	C	.	.	P	.	.	291B956G28	<1>
0	4	.	.	.	C-C	C-C	.	.	.	.	.	291B956G13	129A062G02
0	4	.	C	C	C	C	.	.	.	.	.	291B956G23	<1>
0	4	.	C-A	.	.	.	.	C-A	.	.	.	9666A12G01	<1>
0	4	.	C-C	.	.	C-C	.	.	.	.	.	763A109G01	<1>
0	4	.	C-C	C-C	.	.	.	.	.	.	.	498A027G01	129A062G09
0	4	C	C	C	C	.	.	.	.	.	.	291B956G27	<1>
0	4	C-A	C-A	.	.	.	.	.	.	.	.	9689A12G01	<1>
0	4	C-C	C-C	.	.	.	.	.	.	.	.	291B956G29	<1>
0	4	C-C	C-C	C	.	.	.	.	.	.	.	837A087G01	<1>
<b>5</b>													
Pole		A	B	C	D	E	F	G	H	I	J		
5	0	P	P	.	.	.	.	P	P	P	.	129A505G01	129A062G10
5	0	P	P	P	P	P	.	.	.	.	.	291B957G15	129A062G10
5	0	T	T	.	.	.	.	T	T	T	.	9676A37G01	129A062G10
5	0	T	Y	Z	W	P	.	.	.	.	.	9688A55G01	129A062G10
3	2	P	C-C	P	.	.	.	.	P	.	.	129A508G01	129A062G07
3	2	P	P	.	.	.	.	C-C	P	.	.	129A533G01	129A062G01
3	2	P	P	.	C-C	.	.	.	P	.	.	291B957G17	<1>
3	2	P	P	P	C-C	.	.	.	.	.	.	291B957G16	<1>
3	2	T	P	.	.	.	.	C-C	T	.	.	291B957G09	129A062G01
1	4	.	C	C	.	C	.	C	.	P	.	498A002G01	<1>
1	4	C-C	C-C	C	.	.	.	.	P	.	.	9689A54G01	<1>
0	5	C	.	C	.	C	.	C	.	C	.	129A555G01	<1>
<b>6</b>													
Pole		A	B	C	D	E	F	G	H	I	J		
6	0	.	.	P	P	P	P	P	P	P	.	188A416G01	129A062G10
6	0	P	P	.	.	.	P	P	P	P	.	837A889G01	129A062G10
6	0	P	P	.	P	P	.	P	P	P	.	629A568G01	129A062G10
6	0	P	P	P	.	.	.	P	P	P	.	129A504G01	129A062G10
6	0	P	P	P	P	.	.	.	P	P	.	129A550G01	129A062G10
6	0	P	P	P	P	P	P	.	.	.	.	291B958G25	129A062G10
6	0	P	P	T	.	.	.	T	T	T	.	1586C40G01	129A062G10
6	0	T	T	T	T	.	.	.	P	P	.	9683A81G01	129A062G10

Table 1 - FT-1 Switch Selection Guide (continued)

POTENTIAL CURRENT											STYLE NO.	TEST PLUG
	A	B	C	D	E	F	G	H	I	J		
6 0	T	T	T	T	.	.	.	T	T	.	291B958G33	129A062G10
6 0	T	T	T	T	T	T	.	.	.	.	9676A65G01	129A062G10
6 0	T	Y	O	.	.	.	.	O	Y	T	9688A40G01	129A062G10
6 0	W	W	.	.	P	P	.	.	W	W	9688A04G01	129A062G10
6 0	Z	Z	Z	P	P	.	.	.	.	P	9666A39G01	129A062G10
4 2	P	.	.	.	.	P	P	C-C	P	.	129A509G01	129A062G01
4 2	P	P	P	P	R-R	.	.	.	.	.	9667A02G01	<1>
4 2	T	T	.	.	.	P	P	.	C-C	.	9672A03G01	<1>
3 3	P	P	.	.	.	.	C	C	C	P	291B958G24	<1>
3 3	P	P	.	.	.	.	C	C	C	P	129A543G01	129A062G02
3 3	P	P	P	.	.	.	C	C	C	.	9676A19G01	<1>
2 4	.	.	.	C-C	C-C	P	P	.	.	.	291B958G30	129A062G12
2 4	P	.	.	.	C-C	C-C	P	.	.	.	129A537G01	129A062G02
2 4	P	.	.	.	P	C-C	C-C	.	.	.	291B958G31	<1>
2 4	P	.	.	C	C	C	C	.	.	P	291B958G27	<1>
0 6	.	.	.	C-C	C-C	C-C	.	.	.	.	9672A72G01	<1>
0 6	.	.	.	R-R	7-7	8-8	.	.	.	.	9688A43G01	<1>
0 6	.	.	.	R-R	8-8	7-7	.	.	.	.	9688A30G01	<1>
0 6	.	.	.	8-8	8-8	8-8	.	.	.	.	9689A78G01	292B319G23
0 6	.	.	C	C	C	C	C	C	.	.	188A454G01	<1>
0 6	.	.	C-A	C-A	C-A	.	.	.	.	.	291B958G26	<1>
0 6	.	.	C-A	C-A	C-C	.	.	.	.	.	291B958G29	<1>
0 6	.	.	C-B	C-B	C-B	.	.	.	.	.	498A017G01	<1>
0 6	.	.	C-C	C-C	C-C	.	.	.	.	.	129A516G01	292B319G23
0 6	.	.	R-R	R-R	R-R	.	.	.	.	.	291B958G28	292B319G23
0 6	.	C	C	C	C	C	C	.	.	.	129A523G01	<1>
0 6	.	C-C	.	C-C	.	C-C	.	.	.	.	498A014G01	<1>
0 6	.	C-C	C-C	C-C	.	.	.	.	.	.	9683A76G01	<1>
0 6	C	.	C	.	C	.	C	C	.	.	188A304G01	<1>
0 6	C-C	.	C-C	.	C-C	.	.	.	.	.	9689A23G01	<1>
0 6	C-C	C-C	C-C	.	.	.	.	.	.	.	9660A97G01	<1>
<b>7 Pole</b>												
7 0	.	.	T	T	T	T	T	T	T	T	9688A99G01	129A062G10
7 0	.	P	P	P	P	P	P	.	.	.	129A526G01	129A062G10
7 0	P	.	P	P	P	.	P	P	P	.	129A503G01	129A062G10
7 0	P	.	P	P	P	P	.	P	.	.	291B959G19	129A062G10
7 0	P	P	P	.	.	P	P	P	P	.	129A547G01	129A062G10
7 0	P	P	P	.	.	P	P	P	P	.	291B959G30	129A062G10
7 0	P	P	P	P	.	.	P	P	P	.	498A013G01	129A062G10
7 0	P	P	P	P	P	P	.	.	T	.	9663A79G01	129A062G10
7 0	P	P	P	P	P	P	.	.	.	.	291B959G28	129A062G10
7 0	T	.	P	P	P	.	P	P	T	.	763A168G01	129A062G10
7 0	T	T	P	.	.	P	P	P	P	.	291B959G33	129A062G10
5 2	P	C-C	P	.	.	P	P	P	.	.	188A261G01	129A062G07

POTENTIAL CURRENT											STYLE NO.	TEST PLUG
	A	B	C	D	E	F	G	H	I	J		
5 2	P	P	.	.	C-C	P	P	P	P	.	129A510G01	129A062G08
5 2	P	P	P	P	P	.	.	C-C	.	.	291B959G27	<1>
5 2	P	P	P	P	P	.	.	C-C	.	.	291B959G18	129A062G01
5 2	T	P	.	.	P	P	C-C	T	.	.	188A622G01	129A062G01
5 2	T	T	.	.	R-R	T	T	T	.	.	9667A17G01	129A062G08
4 3	P	P	C	.	C	.	C	.	P	P	188A477G01	292B319G24
3 4	P	C	C	.	C	.	C	.	P	P	188A618G01	<1>
3 4	P	C-C	.	P	.	C-C	.	P	.	.	9688A83G01	<1>
3 4	P	P	.	.	C-C	C-C	P	.	.	.	129A511G01	129A062G02
3 4	P	P	P	.	C-C	C-C	.	.	.	.	498A008G01	129A062G02
3 4	T	C-C	T	C-C	T	.	.	.	.	.	291B959G26	<1>
3 4	T	T	T	.	.	C	C	C	C	.	291B959G32	<1>
3 4	T	T	T	.	C-C	C-C	.	.	.	.	291B959G20	129A062G02
3 4	T	T	T	.	C-C	.	.	C-C	.	.	9676A79G01	<1>
1 6	.	.	C-C	C-C	C-C	T	.	.	.	.	498A003G01	292B319G23
1 6	C-C	C-C	C-C	.	.	T	.	.	.	.	9663A77G01	<1>
1 6	P	C-C	C-B	C-B	.	.	.	.	.	.	129A540G01	<1>
0 7	.	C	C-C	C-C	C-C	.	.	.	.	.	291B959G29	292B319G22
0 7	C-C	C-C	C-C	C	.	.	.	.	.	.	9676A24G01	<1>
<b>8 Pole</b>												
8 0	.	P	P	P	P	P	P	P	P	.	291B960G37	129A062G10
8 0	O	O	O	O	O	O	O	O	.	.	9689A95G01	129A062G10
8 0	P	.	P	P	P	P	P	P	P	.	129A549G01	129A062G10
8 0	P	P	.	P	P	.	P	P	P	P	9689A22G01	129A062G10
8 0	P	P	P	.	P	P	P	P	P	.	719B591G09	129A062G10
8 0	P	P	P	.	P	P	.	P	P	P	291B960G39	129A062G10
8 0	P	P	P	P	.	P	P	P	P	.	129A502G01	129A062G10
8 0	P	P	P	P	.	P	P	P	T	.	129A536G01	129A062G10
8 0	P	P	P	P	P	.	P	P	P	.	129A546G01	129A062G10
8 0	P	P	P	P	P	.	P	T	T	.	719B591G14	129A062G10
8 0	P	P	P	P	P	.	T	T	.	.	9683A80G01	129A062G10
8 0	P	P	P	P	P	P	P	.	.	.	719B591G10	129A062G10
8 0	T	T	.	Z	Z	Z	Z	Z	Z	.	9689A90G01	129A062G10
8 0	T	T	T	.	T	O	O	G	G	.	9689A76G01	129A062G10
8 0	T	T	T	T	.	T	T	T	T	.	9683A10G01	129A062G10
8 0	T	T	T	T	T	.	T	T	T	.	719B591G12	129A062G10
6 2	O	O	C-C	.	Z	Z	Z	Z	.	.	9683A71G01	<1>
6 2	P	P	P	.	C-C	P	P	P	P	.	291B960G26	129A062G08
6 2	P	P	P	P	.	C-C	P	.	.	.	188A632G01	129A062G01
6 2	P	P	P	P	P	.	.	C-C	.	.	291B960G36	<1>
6 2	T	.	P	P	P	P	C-C	T	.	.	763A167G01	129A062G01
6 2	W	W	W	W	W	.	C-C	.	.	.	9689A16G01	<1>
4 4	.	P	P	P	C-C	C-C	P	.	.	.	629A315G01	129A062G02
4 4	C-C	C-C	.	P	P	P	P	.	.	.	719B591G13	<1>

Table 1 - FT-1 Switch Selection Guide (continued)

POTENTIAL CURRENT	A B C D E F G H I J										STYLE NO.	TEST PLUG	
	4	4	C-C	C-C	.	P	P	P	P	.			
4	4	P	C-C	P	.	.	P	C-C	P		129A512G01	129A062G06	
4	4	P	P	.	C	C	C	C	.	P	P	498A016G01	<1>
4	4	P	P	.	C-C	C-C	.	P	P		129A530G01	129A062G12	
4	4	P	P	P	P	.	C-C	C-C	.		129A544G01	129A062G02	
3	5	T	P	.	.	C	C-C	C-C	T		291B960G27	292B319G23	
2	6	.	C	C	C	C	C	C	.	P	P	9667A21G01	<1>
2	6	.	C-C	C-C	C-C	.	P	P			129A521G01	129A062G09	
2	6	.	C-C	C-C	C-C	.	T	T			9683A22G01	129A062G09	
2	6	.	C-C	C-C	C-C	P	P	.			129A525G01	129A062G09	
2	6	C-B	C-B	C-B	.	.	P	P			291B960G38	<1>	
2	6	T	T	.	.	C-C	C-C	C-C	.		9668A69G01	<1>	
2	6	Z	Z	.	.	C-C	C-C	C-C	.		9688A65G01	<1>	
1	7	C	.	.	C-B	C-B	C-B	P			498A018G01	<1>	
1	7	P	.	C	C-C	C-C	C-C	.			498A019G01	292B319G22	
0	8	.	C	C	C	C	C	C	C	.		498A004G01	<1>
0	8	.	C-C	C-C	C-C	C-C	.				129A517G01	292B319G22	
0	8	.	C-C	C-B	.	C-C	C-B				498A029G01	<1>	
0	8	.	C-C	C-B	C-C	C-B	.				291B960G20	<1>	
0	8	.	C-C	C-C	C-C	C-C	.				291B960G33	<1>	
0	8	R-R	R-R	R-R	R-R	R-R	.				9660A84G01	292B319G22	
0	8	5-5	.	.	R-R	7-7	8-8				9688A42G01	<1>	
0	8	5-5-5-A	.	.	5-5-5-A						9689A27G01	<1>	
0	8	C	C	C	C	.	.	C	C	C	188A229G01	<1>	
0	8	C-C	.	.	C-C	C-C	C-C	.			9672A10G01	<1>	
0	8	C-C	C-C	C-C	.	.	C-C				1586C41G01	<1>	
0	8	C-C	C-C	C-C	C-C	.	.				9689A20G01	<1>	
0	8	C-C	C-A	.	.	C-C	C-A				9683A93G01	<1>	
0	8	C-C	C-A	C-C	C-B	.	.				837A099G01	<1>	
0	8	C-C	C-B	.	.	C-C	C-B				498A025G01	<1>	
0	8	C-C	C-C	C-C	C-B	.	.				837A098G01	<1>	
0	8	D	D	D	C-C	C-C	S	.	.		9688A70G01	<1>	
<b>9 Pole</b>													
		<b>A</b>	<b>B</b>	<b>C</b>	<b>D</b>	<b>E</b>	<b>F</b>	<b>G</b>	<b>H</b>	<b>I</b>	<b>J</b>		
9	0	P	P	.	P	P	P	P	P	P	P	129A548G01	129A062G10
9	0	P	P	P	P	.	P	P	P	P	P	129A551G01	129A062G10
9	0	P	P	P	P	P	P	P	P	P	P	9689A21G01	129A062G10
9	0	T	T	T	T	T	T	T	T	T	T	9688A45G01	129A062G10
6	3	P	P	P	C	C	C	P	P	P	.	291B961G23	<1>
6	3	P	P	P	P	P	.	C	C	C	P	291B961G30	<1>
6	3	P	P	P	P	P	.	C	C-C	P		129A552G01	129A062G02
6	3	P	P	P	P	P	.	C-C	C	P		629A483G01	<1>
5	4	P	P	P	P	.	C-C	C-C	P			188A633G01	129A062G02
5	4	P	P	P	P	P	.	C-C	C-C			291B961G22	<1>
5	4	P	P	P	P	P	C	C	C	C	.	291B961G28	<1>

POTENTIAL CURRENT	A B C D E F G H I J										STYLE NO.	TEST PLUG	
	5	4	P	P	P	P	P	C-C	C-C	.			
4	5	P	P	P	P	.	C	C-C	C-B		498A028G01	<1>	
4	5	P	P	P	P	.	C-C	C-C	E		9689A10G01	<1>	
3	6	.	T	C-C	T	C-C	T	C-C			9663A34G01	<1>	
3	6	P	C-C	P	C-C	P	C-C	.			861A551G01	<1>	
3	6	P	P	.	C-C	C-C	C-C	P			129A515G01	292B319G23	
3	6	P	P	P	.	C-C	C-C	C-B			498A024G01	<1>	
3	6	P	P	P	C-C	C-C	.	C	C		291B961G27	<1>	
3	6	P	P	P	C-C	C-C	C-C	.			291B961G29	292B319G23	
3	6	T	T	.	C-C	C-C	C-C	T			9663A74G01	292B319G23	
3	6	T	T	O	.	R-R	8-8	7-7			9689A56G01	<1>	
3	6	T	T	T	.	R-R	8-8	7-7			9689A57G01	<1>	
2	7	P	P	.	C-B	C-B	C-B	S			291B961G26	<1>	
1	8	.	C-C	C-C	C-C	C-C	T				498A009G01	292B319G22	
1	8	T	.	C-C	C-C	C-C	C-C	.			9668A70G01	<1>	
0	9	.	C	C-B	C	C-B	C	C-B			498A023G01	<1>	
0	9	C	C-C	C-C	C-C	C-C	.				498A021G01	<1>	
0	9	C-C	C-C	C-C	C	.	C-C				9676A25G01	<1>	
<b>10 Pole</b>													
		<b>A</b>	<b>B</b>	<b>C</b>	<b>D</b>	<b>E</b>	<b>F</b>	<b>G</b>	<b>H</b>	<b>I</b>	<b>J</b>		
10	0	G	G	G	G	G	G	G	G	G	G	9688A58G01	129A062G10
10	0	G	G	G	G	G	G	G	Y	Y		9689A62G01	129A062G10
10	0	G	G	G	G	G	T	T	T	T		9689A37G01	129A062G10
10	0	G	G	G	G	G	T	T	T	T		9688A57G01	129A062G10
10	0	G	G	G	G	Y	Y	Y	Y	Y		9688A26G01	129A062G10
10	0	G	G	G	G	Z	Z	Z	Z	Z		9683A88G01	129A062G10
10	0	G	G	G	P	P	T	T	T	T		9688A56G01	129A062G10
10	0	G	G	G	Y	Y	Y	Y	Y	Y		9683A69G01	129A062G10
10	0	G	T	T	G	T	T	T	T	T		9689A65G01	129A062G10
10	0	G	T	T	T	T	T	T	T	T		9689A59G01	129A062G10
10	0	G	Y	T	T	T	G	T	T	T		9689A99G01	129A062G10
10	0	O	G	O	P	P	P	P	P	P		9688A13G01	129A062G10
10	0	O	O	O	O	O	O	O	O	O		9672A97G01	129A062G10
10	0	O	O	O	O	O	Y	Y	Y	Y		9688A08G01	129A062G10
10	0	O	O	T	T	T	T	P	P	P		9683A61G01	129A062G10
10	0	O	W	Z	Z	G	W	Y	Y	W	W	9683A18G01	129A062G10
10	0	P	P	P	P	P	P	O	O	T	T	9688A90G01	129A062G10
10	0	P	P	P	P	P	P	P	P	P	P	129A501G01	129A062G10
10	0	P	P	P	P	P	P	P	P	T		774B430G19	129A062G10
10	0	P	P	P	P	P	P	P	T	P		9676A88G01	129A062G10
10	0	P	P	P	P	P	P	P	T	T		1586C42G23	129A062G10
10	0	P	P	P	P	P	P	P	Z	Z		9671A94G01	129A062G10
10	0	P	P	P	P	P	P	T	T	P		9672A77G01	129A062G10
10	0	P	P	P	P	P	P	T	T	T		1586C42G25	129A062G10
10	0	P	P	P	P	P	T	P	P	P		1586C42G29	129A062G10

Table 1 - FT-1 Switch Selection Guide (continued)

POTENTIAL	CURRENT											STYLE NO.	TEST PLUG
		A	B	C	D	E	F	G	H	I	J		
10	0	P	P	P	P	P	T	P	P	T		9676A08G01	129A062G10
10	0	P	P	P	P	P	T	P	T	P		9672A75G01	129A062G10
10	0	P	P	P	P	P	T	P	T	T		1586C42G30	129A062G10
10	0	P	P	P	P	P	T	T	T	P		9672A98G01	129A062G10
10	0	P	P	P	P	P	T	T	T	T		9672A71G01	129A062G10
10	0	P	P	P	P	P	Z	Z	G	T		9688A59G01	129A062G10
10	0	P	P	P	P	P	Z	Z	Z	Z		9671A95G01	129A062G10
10	0	P	P	P	P	T	P	T	P	T		9676A97G01	129A062G10
10	0	P	P	P	P	T	T	T	T	T		1586C42G24	129A062G10
10	0	P	P	P	P	T	T	T	T	T		670B197G21	129A062G10
10	0	P	P	P	P	T	P	P	P	P		9688A16G01	129A062G10
10	0	P	P	P	P	T	P	P	P	P		9688A96G01	129A062G10
10	0	P	P	P	P	T	P	P	T	P		9667A06G01	129A062G10
10	0	P	P	P	P	T	P	T	T	T		1586C42G28	129A062G10
10	0	P	P	P	P	T	T	P	P	P		9688A95G01	129A062G10
10	0	P	P	P	P	T	T	T	P	P		9676A14G01	129A062G10
10	0	P	P	P	P	T	T	T	T	P		9688A28G01	129A062G10
10	0	P	P	P	P	T	T	T	T	P		9688A15G01	129A062G10
10	0	P	P	P	P	T	T	T	T	T		670B197G26	129A062G10
10	0	P	P	P	P	W	W	T	T	T		9683A95G01	129A062G10
10	0	P	P	P	T	P	P	P	P	P		9689A79G01	129A062G10
10	0	P	P	P	T	T	T	T	T	P		9672A74G01	129A062G10
10	0	P	P	P	T	T	T	T	T	T		9689A32G01	129A062G10
10	0	P	P	T	P	P	P	P	P	P		9676A90G01	129A062G10
10	0	P	P	T	P	T	P	P	P	P		1586C42G15	129A062G10
10	0	P	P	T	T	T	P	P	T	T		9689A97G01	129A062G10
10	0	P	P	T	T	T	T	P	P	P		9664A98G01	129A062G10
10	0	P	P	T	T	T	T	T	P	P		9664A97G01	129A062G10
10	0	P	P	T	T	T	T	T	T	T		670B197G24	129A062G10
10	0	P	T	P	P	P	P	P	P	P		9688A20G01	129A062G10
10	0	P	T	P	P	P	P	P	T	T		9688A19G01	129A062G10
10	0	P	T	P	P	T	P	P	T	P		9668A27G01	129A062G10
10	0	P	T	P	P	T	P	P	T	P		9667A03G01	129A062G10
10	0	P	T	P	T	P	P	T	P	T		9670A98G01	129A062G10
10	0	P	T	T	P	P	P	P	P	P		9671A69G01	129A062G10
10	0	P	T	T	P	P	P	T	T	T		9688A18G01	129A062G10
10	0	P	T	T	T	P	P	T	T	P		9676A53G01	129A062G10
10	0	P	T	T	T	T	T	T	T	T		9688A17G01	129A062G10
10	0	P	T	W	Z	P	P	T	W	Z	P	9683A97G01	129A062G10
10	0	P	W	T	G	O	Z	T	T	T		9688A84G01	129A062G10
10	0	T	G	T	Z	Z	Z	Z	Z	Z		9688A12G01	129A062G10
10	0	T	O	Y	T	Z	O	O	T	Y	T	9688A44G01	129A062G10
10	0	T	P	P	P	P	P	P	P	P		1586C42G31	129A062G10
10	0	T	P	P	P	P	P	P	P	T		670B197G36	129A062G10
10	0	T	P	P	P	P	P	P	P	W		9664A92G01	129A062G10

POTENTIAL	CURRENT											STYLE NO.	TEST PLUG
		A	B	C	D	E	F	G	H	I	J		
10	0	T	P	P	P	P	T	P	P	P		9667A93G01	129A062G10
10	0	T	P	P	T	P	P	P	P	P		9670A35G01	129A062G10
10	0	T	P	P	T	P	P	T	P	P		9670A34G01	129A062G10
10	0	T	P	P	T	P	P	T	P	P		9670A97G01	129A062G10
10	0	T	P	T	P	P	P	P	P	P		1586C42G06	129A062G10
10	0	T	P	T	P	P	P	T	P	T		1586C42G46	129A062G10
10	0	T	P	T	P	T	P	P	P	P		9676A87G01	129A062G10
10	0	T	P	T	P	T	P	T	P	P		9676A89G01	129A062G10
10	0	T	P	T	P	T	P	T	P	T		9668A54G01	129A062G10
10	0	T	P	T	T	P	T	P	T	P		9676A34G01	129A062G10
10	0	T	T	G	G	G	G	G	G	G		9689A49G01	129A062G10
10	0	T	T	G	G	G	T	T	T	T		9689A50G01	129A062G10
10	0	T	T	G	T	T	T	T	T	T		9676A72G01	129A062G10
10	0	T	T	O	O	Y	Y	T	T	G		9688A10G01	129A062G10
10	0	T	T	P	P	P	P	P	P	P		1586C42G45	129A062G10
10	0	T	T	P	P	P	P	P	P	T		9667A78G01	129A062G10
10	0	T	T	P	P	P	P	P	T	T		1586C42G41	129A062G10
10	0	T	T	P	P	P	P	T	P	P		9660A92G01	129A062G10
10	0	T	T	P	P	P	T	T	P	P		9671A68G01	129A062G10
10	0	T	T	P	P	T	T	P	T	T		9667A86G01	129A062G10
10	0	T	T	T	G	G	T	P	P	Z		9689A70G01	129A062G10
10	0	T	T	T	P	P	P	P	P	P		9676A84G01	129A062G10
10	0	T	T	T	P	P	P	T	T	T		9663A25G01	129A062G10
10	0	T	T	T	S	T	S	O	O	G		9689A88G01	<1>
10	0	T	T	T	T	P	P	P	P	P		670B197G31	129A062G10
10	0	T	T	T	T	P	P	T	T	T		9689A31G01	129A062G10
10	0	T	T	T	T	T	P	P	P	P		9671A13G01	129A062G10
10	0	T	T	T	T	T	T	P	P	P		716B562G10	129A062G10
10	0	T	T	T	T	T	T	P	P	Z		9689A69G01	129A062G10
10	0	T	T	T	T	T	T	O	T	T		9689A60G01	129A062G10
10	0	T	T	T	T	T	T	T	P	P		1586C42G44	129A062G10
10	0	T	T	T	T	T	T	T	T	T		129A539G01	129A062G10
10	0	T	T	T	T	T	Y	Y	Y	Y		9683A03G01	129A062G10
10	0	T	T	T	T	T	Z	Z	Z	Z		9672A02G01	129A062G10
10	0	T	T	T	T	T	Z	Z	Z	Z		9683A06G01	129A062G10
10	0	T	T	T	T	Z	T	T	T	T		9664A79G01	129A062G10
10	0	T	T	T	T	Z	Z	G	G	G		9689A61G01	129A062G10
10	0	T	T	T	T	Z	Z	Z	Z	Z		9688A93G01	129A062G10
10	0	T	T	T	Y	Y	P	P	P	P		9676A74G01	129A062G10
10	0	T	T	T	Z	Z	T	T	T	T		9664A78G01	129A062G10
10	0	T	T	Y	Y	P	P	P	P	P		9676A73G01	129A062G10
10	0	T	T	Y	Y	Z	Z	Z	T	P		9689A08G01	129A062G10
10	0	T	T	Z	Z	P	P	T	G	O		9664A88G01	129A062G10
10	0	T	Y	Z	P	P	P	P	O	O		9666A36G01	129A062G10
10	0	T	Y	Z	T	Y	Z	T	Y	Z		9689A40G01	129A062G10

Table 1 - FT-1 Switch Selection Guide (continued)

POTENTIAL CURRENT	A	B	C	D	E	F	G	H	I	J	STYLE NO.	TEST PLUG
10 0	T	Y	Z	W	G	G	G	G	G	G	9689A36G01	129A062G10
10 0	T	Y	Z	W	G	G	G	G	G	P	9688A54G01	129A062G10
10 0	T	Y	Z	W	P	P	P	G	G	G	9688A52G01	129A062G10
10 0	T	Y	Z	W	P	P	P	P	P	P	9688A53G01	129A062G10
10 0	T	Y	Z	W	T	Y	Z	W	P	P	9666A13G01	<1>
10 0	T	Z	P	O	T	G	W	P	O	G	9664A84G01	129A062G10
10 0	W	W	O	O	Y	Y	Z	Z	Y	W	9647A22G01	129A062G10
10 0	W	W	T	T	T	G	P	P	P	P	9647A21G01	129A062G10
10 0	W	W	T	T	Y	Z	Y	O	O	Y	9649A37G01	129A062G10
10 0	W	W	T	T	T	T	T	T	T	T	9641A64G01	129A062G10
10 0	W	W	W	W	W	W	W	W	T		9646A77G01	129A062G10
10 0	W	W	W	W	W	W	W	W	W		9676A93G01	129A062G10
10 0	W	W	W	W	Y	Y	Y	Y	Y		9689A63G01	129A062G10
10 0	W	W	W	Y	Y	Y	Y	G	G		9688A66G01	129A062G10
10 0	W	Y	Z	Z	Y	Y	G	T	T		9683A17G01	129A062G10
10 0	W	Y	Z	Z	Y	Y	O	W	W		9683A19G01	129A062G10
10 0	Y	G	Y	G	Y	Y	W	W	W		9688A14G01	129A062G10
10 0	Y	Y	W	W	W	W	W	W	W		9688A82G01	129A062G10
10 0	Y	Y	W	W	W	Y	Y	Y	Y		9688A73G01	129A062G10
10 0	Y	Y	W	Y	Y	W	Y	Y	Y		9688A72G01	129A062G10
10 0	Y	Y	Y	Y	W	W	W	W	W		9688A71G01	129A062G10
10 0	Y	Y	Y	Y	W	Y	Y	Y	Y		9689A47G01	129A062G10
10 0	Y	Y	Y	Y	T	T	T	T	T		9688A09G01	129A062G10
10 0	Y	Y	Y	Y	W	W	W	W	W		9688A81G01	129A062G10
10 0	Y	Y	Y	Y	Y	W	W	W	W		9688A78G01	129A062G10
10 0	Y	Y	Y	Y	Y	W	Y	Y	Y		9688A80G01	129A062G10
10 0	Y	Y	Y	Y	Y	Y	T	T	T		9689A13G01	129A062G10
10 0	Y	Y	Y	Y	Y	Y	G	G	G		9688A24G01	129A062G10
10 0	Y	Y	Y	Y	Y	Y	W	W	W		9688A77G01	129A062G10
10 0	Y	Y	Y	Y	Y	Y	Y	Y	Y		9683A01G01	129A062G10
10 0	Y	Y	Z	Z	Z	Z	Z	T	P		9689A09G01	129A062G10
10 0	Z	Z	G	G	G	G	G	W	W		9683A75G01	129A062G10
10 0	Z	Z	G	G	G	W	W	Y	Y		9683A70G01	129A062G10
10 0	Z	Z	G	G	W	W	W	W	W		9688A23G01	129A062G10
10 0	Z	Z	G	G	W	Y	Y	Y	W		9688A74G01	129A062G10
10 0	Z	Z	W	W	W	W	W	W	W		9688A76G01	129A062G10
10 0	Z	Z	W	W	W	W	Y	Y	Y		9683A02G01	129A062G10
10 0	Z	Z	Y	Y	Y	Y	Y	G	W		9663A41G01	129A062G10
10 0	Z	Z	Z	O	O	O	O	O	O		9688A89G01	129A062G10
10 0	Z	Z	Z	Z	O	O	O	O	O		9688A88G01	129A062G10
10 0	Z	Z	Z	Z	Z	O	O	O	O		9689A15G01	129A062G10
10 0	Z	Z	Z	Z	Z	Z	O	O	O		9688A92G01	129A062G10
10 0	Z	Z	Z	Z	Z	Z	Z	O	O		9689A91G01	129A062G10
10 0	Z	Z	Z	Z	Z	Z	Z	P	P		9676A81G01	129A062G10
10 0	Z	Z	Z	Z	Z	Z	Z	W	W		9676A91G01	129A062G10

POTENTIAL CURRENT	A	B	C	D	E	F	G	H	I	J	STYLE NO.	TEST PLUG
10 0	Z	Z	Z	Z	Z	Z	Z	Z	Z	Z	9676A94G01	129A062G10
9 1	C	P	P	P	P	P	P	P	P	P	498A011G01	<1>
9 1	C	T	T	T	T	T	T	T	T	T	1586C42G39	<1>
9 1	O	Y	C	W	G	P	P	T	T	T	9647A19G01	129A062G10
8 2	C-A	P	P	P	P	P	P	P	P	P	714B325G31	<1>
8 2	C-C	P	P	P	P	P	P	P	P	P	837A665G01	<1>
8 2	C-C	P	P	P	P	T	T	T	T	T	9647A12G01	<1>
8 2	C-C	P	P	T	T	T	T	T	T	T	9647A11G01	<1>
8 2	C-C	T	T	P	P	P	P	P	P	P	9676A86G01	<1>
8 2	C-C	T	T	P	P	T	T	P	P	P	9688A07G01	<1>
8 2	C-C	T	T	T	T	P	P	P	P	P	9647A98G01	<1>
8 2	C-C	T	T	T	T	T	T	P	P	P	9683A72G01	<1>
8 2	C-C	T	T	T	T	T	T	T	T	T	1586C42G20	<1>
8 2	P	C	C	P	P	T	P	P	P	P	1586C42G32	<1>
8 2	P	P	C	C	P	P	P	P	P	P	670B197G33	<1>
8 2	P	P	P	C	C	P	P	P	P	P	716B562G21	<1>
8 2	P	P	P	P	P	C	C	P	P	P	9689A72G01	<1>
8 2	P	P	P	P	P	8-8	Z	Z	Z	Z	9666A28G01	<1>
8 2	P	P	P	P	P	C	C	P	P	P	9663A60G01	<1>
8 2	P	P	P	P	P	P	C	C	P		129A542G01	129A062G01
8 2	P	P	P	P	P	P	C	C	T		1586C42G38	129A062G01
8 2	P	P	P	P	P	P	P	C	A		714B325G30	<1>
8 2	P	P	P	P	P	P	P	C	C		716B562G26	<1>
8 2	P	P	P	P	P	P	R	R	P		9676A15G01	129A062G01
8 2	P	P	P	P	T	T	P	C	C	P	716B562G35	129A062G01
8 2	P	P	R	R	T	P	P	P	P	P	9689A25G01	<1>
8 2	P	P	T	T	T	T	T	T	C	C	9688A98G01	<1>
8 2	T	P	P	P	P	P	C	C	P		9672A83G01	129A062G01
8 2	T	P	P	P	P	P	C	C	T		1586C42G26	129A062G01
8 2	T	T	C	C	P	G	Y	W	Z	O	9676A04G01	<1>
8 2	T	T	R	A	T	T	T	T	T	T	9689A87G01	<1>
8 2	T	T	T	T	C	C	T	T	T	T	1586C42G33	<1>
8 2	T	T	T	T	T	T	C	A	T	T	9688A62G01	<1>
8 2	T	T	T	T	T	T	R	R	T	T	9666A34G01	<1>
8 2	T	T	T	T	T	T	C	C	T		1586C42G47	129A062G01
8 2	T	T	T	T	T	T	R	R	T		670B197G17	129A062G01
8 2	T	T	T	T	T	T	T	C	C		9672A89G01	<1>
7 3	P	P	P	P	P	P	C	C	C	P	129A553G01	<1>
6 4	6-6	7-7	G	Y	Z	W	O	W	W	W	9666A27G01	<1>
6 4	C	C	P	P	P	P	P	C	C	C	716B562G20	<1>
6 4	C-A	C-A	P	P	P	P	P	P	P	P	714B325G27	<1>
6 4	C-C	C-C	P	P	P	P	P	P	P	P	498A015G01	<1>
6 4	C-C	C-C	P	P	P	P	P	T	T	T	1586C42G13	<1>
6 4	C-C	C-C	P	P	P	P	T	T	T	T	9672A80G01	<1>
6 4	C-C	C-C	P	P	T	T	T	T	T	T	9676A06G01	<1>

Table 1 - FT-1 Switch Selection Guide (continued)

POTENTIAL	CURRENT											STYLE NO.	TEST PLUG
		A	B	C	D	E	F	G	H	I	J		
6	4	C	C	C	C	T	T	T	T	T	T	9663A31G01	<1>
6	4	C	C	P	P	C	C	P	P	P	P	716B562G17	<1>
6	4	C	C	P	P	P	P	C	C	P	P	716B562G19	<1>
6	4	C	C	P	P	P	P	P	P	C	C	877A077G01	<1>
6	4	C	C	C	A	T	T	T	T	T	T	9683A94G01	<1>
6	4	C	C	C	C	P	P	P	P	P	T	1586C42G11	<1>
6	4	C	C	C	C	P	P	P	P	T	T	1586C42G12	<1>
6	4	C	C	C	C	T	T	T	T	T	T	9672A99G01	<1>
6	4	C	C	C	C	W	W	W	T	T	T	9689A38G01	<1>
6	4	C	C	C	E	T	T	T	T	T	T	9672A87G01	<1>
6	4	O	O	P	P	P	R	-6	-7	-C		9666A37G01	<1>
6	4	P	C	C	C	C	P	P	P	P	P	716B562G36	<1>
6	4	P	C	C	P	P	P	P	C	C	P	129A513G01	129A062G06
6	4	P	C	C	P	P	P	P	C	C	T	629A735G01	129A062G06
6	4	P	C	C	P	P	P	T	C	C	P	1586C42G22	129A062G06
6	4	P	C	C	P	P	T	T	C	C	T	1586C42G27	129A062G06
6	4	P	C	C	C	C	P	P	P	P	P	836A867G01	<1>
6	4	P	P	C	A	C	A	P	P	P	P	714B325G28	<1>
6	4	P	P	C	C	P	P	C	C	P	P	716B562G15	<1>
6	4	P	P	P	C	C	C	P	P	P	P	9689A81G01	129A062G12
6	4	P	P	P	C	C	P	P	C	C	P	129A520G01	129A062G05
6	4	P	P	P	P	C	C	C	C	P	P	9689A01G01	<1>
6	4	P	P	P	P	C	A	C	A	P	P	714B325G29	<1>
6	4	P	P	P	P	C	C	C	C	P	P	670B197G19	<1>
6	4	P	P	P	P	C	C	P	P	C	C	670B197G34	<1>
6	4	P	P	P	P	P	C	C	C	C	P	129A532G01	129A062G02
6	4	P	P	P	P	P	C	A	C	A		714B325G16	<1>
6	4	P	P	P	P	P	C	C	C	A		714B325G18	<1>
6	4	P	P	P	P	P	C	C	C	C		670B197G28	<1>
6	4	P	P	T	P	P	C	C	C	C	P	9676A09G01	129A062G02
6	4	P	P	T	P	T	P	C	C	C	C	1586C42G14	<1>
6	4	P	T	P	R	C	P	P	R	C	P	9676A71G01	129A062G05
6	4	R	A	R	A	T	T	T	T	T	T	9689A73G01	<1>
6	4	R	R	R	R	T	T	T	T	T	T	670B197G25	<1>
6	4	T	P	C	P	C	P	C	P	C	P	670B197G37	292B319G22
6	4	T	P	P	C	C	P	P	C	C	P	9660A91G01	129A062G05
6	4	T	P	P	C	C	T	P	P	C	C	9676A05G01	<1>
6	4	T	P	P	P	P	C	C	C	C	T	849A307G01	<1>
6	4	T	T	T	R	R	T	T	R	R	T	861A670G01	129A062G05
6	4	T	Y	Z	T	Y	Z	R	-6	-7	-C	9689A42G01	<1>
6	4	Z	Z	O	O	O	O	C	C	C	C	9689A18G01	<1>
5	5	P	P	C	C	C	P	C	C	P	P	670B197G20	<1>
4	6	C	C	C	C	C	P	P	P	P	P	774B430G18	<1>

POTENTIAL	CURRENT											STYLE NO.	TEST PLUG
		A	B	C	D	E	F	G	H	I	J		
4	6	C	C	C	C	C	T	T	T	T	T	1586C42G21	<1>
4	6	C	C	C	C	C	G	T	T	T	T	9683A15G01	<1>
4	6	C	C	C	C	C	O	O	W	W		9683A21G01	<1>
4	6	C	C	C	C	C	O	Y	W	W		9683A20G01	<1>
4	6	C	C	C	C	C	P	P	P	P	P	774B430G20	<1>
4	6	C	C	C	C	C	P	P	P	T		1586C42G36	<1>
4	6	C	C	C	C	C	P	P	T	T		9671A70G01	<1>
4	6	C	C	C	C	C	T	T	P	P		9683A73G01	<1>
4	6	C	C	C	C	C	T	T	T	T		774B430G24	<1>
4	6	C	C	P	P	C	C	P	P	C	C	716B562G16	<1>
4	6	C	C	T	P	C	C	C	C	P	T	1586C42G10	<1>
4	6	C	C	C	C	C	P	P	P	P	P	774B430G09	<1>
4	6	C	C	C	C	C	P	T	P	T		9676A98G01	<1>
4	6	C	C	C	D	P	L	C	C	T	T	9683A98G01	<1>
4	6	L	L	L	L	C	E	C	E	C	E	9660A96G01	<1>
4	6	O	G	T	W	C	C	C	C	C	C	9676A99G01	<1>
4	6	O	O	O	O	C	C	C	C	C	C	9689A14G01	<1>
4	6	O	Y	Y	O	C	C	C	C	C	C	9666A20G01	<1>
4	6	O	Y	Z	8	-9	8	-6	8	-7	P	9683A05G01	292B319G23
4	6	P	C	A	P	C	A	P	C	A	P	9689A04G01	<1>
4	6	P	C	C	C	C	C	P	P	P	P	716B562G37	129A062G09
4	6	P	C	C	C	C	C	P	P	P	P	774B430G10	129A062G09
4	6	P	C	C	P	C	C	P	C	C	P	129A528G01	<1>
4	6	P	G	T	C	C	5	-5	R	R	W	9676A58G01	292B319G23
4	6	P	P	C	C	C	C	C	P	P		774B430G21	<1>
4	6	P	P	C	C	C	C	C	P	P		714B325G19	<1>
4	6	P	P	C	C	P	P	C	C	C	C	716B562G18	<1>
4	6	P	P	P	6	-6	6	-6	6	-6	P	9664A93G01	292B319G23
4	6	P	P	P	C	C	C	C	C	C	P	9670A05G01	<1>
4	6	P	P	P	C	A	C	A	C	A	P	9688A22G01	292B319G23
4	6	P	P	P	C	A	P	C	C	C	A	714B325G17	<1>
4	6	P	P	P	C	C	C	C	C	P		129A514G01	292B319G23
4	6	P	P	P	C	C	C	C	T			670B197G32	292B319G23
4	6	P	P	P	C	C	C	C	Z			9671A93G01	292B319G23
4	6	P	P	P	C	C	C	R	C	R	T	1586C42G34	292B319G23
4	6	P	P	P	C	C	P	C	C	C	C	670B197G27	<1>
4	6	P	P	P	G	R	R	R	R	R	R	9688A01G01	<1>
4	6	P	P	P	P	C	A	C	A	C	A	714B325G24	<1>
4	6	P	P	P	P	C	C	C	C	C	C	1586C42G05	<1>
4	6	P	P	P	P	P	C	C	C	C	C	670B197G18	<1>
4	6	P	P	P	P	P	C	C	C	C	C	1586C42G37	<1>
4	6	P	P	P	P	P	P	C	C	C	C	670B197G23	<1>
4	6	P	P	P	P	R	R	R	R	R	R	9660A85G01	<1>

Table 1 - FT-1 Switch Selection Guide (continued)

POTENTIAL	CURRENT											STYLE NO.	TEST PLUG
		A	B	C	D	E	F	G	H	I	J		
4	6	P	P	P	R-R	R-R	R-R	R-R	P			1586C42G03	292B319G23
4	6	P	P	P	R-R	R-R	R-R	W				9688A38G01	292B319G23
4	6	P	P	T	C-C	C-C	C-C	T				1586C42G48	292B319G23
4	6	P	R-R	P	R-R	P	R-R	P				9676A17G01	<1>
4	6	P	T	Z	C-7	8-7	7-C	P				9676A55G01	292B319G23
4	6	P	T	Z	C-8	R-8	7-8	W				9676A68G01	292B319G23
4	6	P	T	Z	W	6-5	8-5	9-5				9689A53G01	<1>
4	6	R-B	R-B	R-B	T	T	T	T				714B325G20	<1>
4	6	R-R	7-7	C-C	G	Y	T	P				9664A89G01	<1>
4	6	R-R	7-7	C-C	G	Y	W	O				9664A81G01	<1>
4	6	R-R	7-7	C-C	T	G	O	G				9664A87G01	<1>
4	6	R-R	7-7	C-C	T	Z	P	O				9664A86G01	<1>
4	6	R-R	7-7	C-C	W	P	T	G				9664A85G01	<1>
4	6	R-R	R-R	R-R	P	P	P	P				9689A33G01	<1>
4	6	R-R	R-R	R-R	T	T	T	T				9688A11G01	<1>
4	6	T	5-A	T	5-A	T	5-A	T				9689A28G01	<1>
4	6	T	C-C	C-C	C-C	P	P	P				9676A60G01	129A062G09
4	6	T	C-C	T	C-C	T	C-C	T				188A523G01	<1>
4	6	T	C-C	T	C-C	T	C-C	Y				9689A84G01	<1>
4	6	T	P	C-C	C-C	C-C	P	P				1586C42G18	<1>
4	6	T	P	P	P	C-C	C-C	C-C				9664A80G01	<1>
4	6	T	P	P	P	C-C	C-R	C-C				9689A89G01	<1>
4	6	T	P	Z	W	R-R	C-C	7-7				9688A87G01	<1>
4	6	T	T	C-C	C-C	C-C	T	T				9667A22G01	<1>
4	6	T	T	P	C-C	C-C	C-C	P				9689A07G01	292B319G23
4	6	T	T	P	C-C	C-C	C-C	T				9667A80G01	292B319G23
4	6	T	T	P	P	C-C	C-C	C-C				9672A90G01	<1>
4	6	T	T	T	5-A	5-A	5-A	T				9689A29G01	292B319G23
4	6	T	T	T	C-C	C-C	C-C	N				291B961G25	<1>
4	6	T	T	T	C-C	C-C	C-C	P				9667A69G01	292B319G23
4	6	T	T	T	C-C	C-C	C-C	T				714B325G32	292B319G23
4	6	T	T	T	C-C	C-C	C-C	W				9676A35G01	292B319G23
4	6	T	T	T	G	C-C	C-C	C-C				9647A23G01	<1>
4	6	T	T	T	P	C-C	C-C	C-C				9676A80G01	<1>
4	6	T	T	T	R-R	R-R	R-R	T				774B430G13	292B319G23
4	6	T	T	T	T	C-C	C-C	C-C				498A010G01	<1>
4	6	T	T	T	T	C-C	C-C	C-C				9676A10G01	<1>
4	6	T	W	Z	G	R-R	7-7	8-8				9688A41G01	<1>
4	6	T	W	Z	G	R-R	8-8	7-7				9683A07G01	<1>
4	6	T	W	Z	R-R	8-8	7-7	P				9683A04G01	292B319G23
4	6	T	Y	Z	8-C	P	R-6	7-C				9689A41G01	<1>
4	6	T	Y	Z	W	C-C	C-C	C-C				9689A06G01	<1>
4	6	W	W	O	Y	C-C	C-C	C-C				9666A21G01	<1>

POTENTIAL	CURRENT											STYLE NO.	TEST PLUG
		A	B	C	D	E	F	G	H	I	J		
4	6	W	W	Y	O	C-C	C-C	C-C				9647A20G01	<1>
4	6	Z	R-R	Z	R-R	Z	R-R	P				9666A38G01	<1>
4	6	Z	Z	O	O	C-C	C-C	C-C				9689A19G01	<1>
4	6	Z	Z	Z	C-C	C-C	C-C	Z				9672A01G01	292B319G23
4	6	Z	Z	Z	W	R-R	6-6	5-5				9689A85G01	<1>
4	6	Z	Z	Z	Z	C-C	C-C	C-C				9676A95G01	<1>
4	8	W	W	W	W	C-C	C-C	C-C				9688A02G01	<1>
3	3	P	P	P	U	C	U	C	U	U		1485B70G09	<1>
3	6	L	L	L	U	C-E	C-E	C-E				1485B70G10	<1>
3	6	P	P	P	C-B	C-B	C-B	S				716B562G30	<1>
3	6	P	P	P	S	C-C	C-C	C-C				774B430G16	<1>
3	6	T	T	T	C-C	C-C	C-C	U				1485B70G11	<1>
3	7	9-C	6-C	7-C	8	P	G	P				9683A96G01	<1>
3	7	C-C	C-C	C-C	C	P	P	P				1586C42G43	<1>
3	7	C-C	P	C-C	P	C-C	P	C				714B325G22	<1>
3	7	P	G	T	C-C	5-5	R-R	8				9676A76G01	<1>
3	7	P	P	C	C-C	C	C-C	C	P			716B562G12	<1>
3	7	P	P	C	C-C	C-C	C-C	P				129A535G01	292B319G22
3	7	P	P	C	C-C	C-C	C-C	T				9672A86G01	292B319G22
3	7	P	P	P	C	C	C	C	C			1586C42G17	<1>
3	7	P	P	P	C	C-C	C-C	C-C				9671A26G01	<1>
3	7	P	P	P	C-C	C-C	C-C	C				1586C42G19	<1>
3	7	P	P	P	C-C	C-C	C-C	C				714B325G11	<1>
3	7	P	P	P	C-C	C-C	C-C	C				714B325G25	<1>
3	7	P	T	C	C-C	C-C	C-C	T				670B197G22	292B319G22
3	7	T	T	C	C-C	C-C	C-C	T				670B197G35	292B319G22
3	7	T	T	C-C	C-C	C-C	C	T				9688A86G01	<1>
3	7	T	T	T	C-C	5-5	R-R	8				9689A45G01	<1>
3	7	T	T	T	C-C	C-C	C-C	C				9663A59G01	<1>
3	7	T	T	T	R-R	R-R	R-R	R				9688A50G01	<1>
2	7	P	S	P	R-R	R-R	R-R	C				9676A83G01	<1>
2	8	5-5	5-5	5-5	5-5	5-5	G	G				9683A87G01	<1>
2	8	7-7	7-7	7-7	7-7	Z	Z	Z				9683A89G01	<1>
2	8	8-C	R-C	5-C	9-C	T	T	T				9688A85G01	<1>
2	8	9-C	6-C	7-C	C-C	T	T	T				9647A18G01	<1>
2	8	C	C	C	C	C	C	C	P	P		9689A02G01	<1>
2	8	C-A	P	P	C	C-C	C	C-C				714B325G21	<1>
2	8	C-C	C-C	C-C	C-C	P	P	T				837A407G01	<1>
2	8	C-C	C-C	C-C	C-C	P	T	T				9672A95G01	<1>
2	8	C-C	C-C	C-C	C-C	T	P	T				9676A11G01	<1>
2	8	C-C	C-C	C-C	C-C	T	T	T				774B430G22	<1>
2	8	C-C	C-C	C-C	C-C	W	W	W				9683A16G01	<1>
2	8	C-C	C-C	P	C	C	C	C	P			837A664G01	<1>
2	8	C-C	P	P	C	C-C	C	C-C				716B562G24	<1>
2	8	C-C	T	C-C	C-C	C-C	P					9688A94G01	<1>

Table 1 - FT-1 Switch Selection Guide (continued)

POTENTIAL	CURRENT											STYLE NO.	TEST PLUG
		A	B	C	D	E	F	G	H	I	J		
2	8	C-C	T	C-C	C-C	C-C	T					9667A68G01	<1>
2	8	C-C-C-B	C-C-C-B	P	P							498A031G01	<1>
2	8	C-C-C-C	C	C	C-C	P	P					716B562G38	<1>
2	8	C-C-C-C	C-C	C-C	P	P						714B325G15	<1>
2	8	C-C-C-C	C-C-C-B	P	P							837A101G01	<1>
2	8	C-C-C-C	C-C-C-B	T	T							1586C42G42	<1>
2	8	C-C-C-C	C-C-C-C	P	P							774B430G11	<1>
2	8	C-C-C-C	C-C-C-C	P	T							1586C42G09	<1>
2	8	C-C-C-C	C-C-C-C	T	P							9671A22G01	<1>
2	8	C-C-C-C	C-C-C-C	T	T							9642A36G01	<1>
2	8	C-C-C-C	P	C-C-C-C	P							9672A94G01	<1>
2	8	C-C-C-C	T	C-C-C-C	T							9676A01G01	<1>
2	8	C-C-C-D	C-C-C-B	P	P							498A032G01	<1>
2	8	C-C-C-D	C-C-C-D	P	P							714B325G13	<1>
2	8	C-C-C-D	C-C-C-D	P	P							774B430G12	<1>
2	8	C-C-C-E	C-C-C-E	T	T							9672A23G01	<1>
2	8	C-C-C-E	T	C-C-C-E	T							9672A88G01	<1>
2	8	C-C-E	C	C-C	C-C	P	P					716B562G39	<1>
2	8	L	C-E	C-E	C-E	C-E	L					9666A23G01	<1>
2	8	P	C	C	C	C	C	C	P			129A519G01	<1>
2	8	P	C	C	C	P	C	C	C			716B562G27	<1>
2	8	P	C-C	C-C	C-C	C-C	P					129A518G01	292B319G22
2	8	P	C-C	C-C	C-C	C-C	T					1586C42G08	292B319G22
2	8	P	C-C	C-C	C-C	C-C	T					837A616G01	292B319G22
2	8	P	P	C-C	C-C	C-C	C-C					716B562G25	<1>
2	8	P	P	C-C-C-C	C-C-C-C							9676A96G01	<1>
2	8	P	R-R	R-R	R-R	R-R	P					9683A99G01	292B319G22
2	8	R-6-7-C	R-6-7-C	O	O							9666A35G01	<1>
2	8	R-B	R-B	R-B	R-B	T	T					714B325G12	<1>
2	8	R-C	R-C	R-C	R-C	T	T					716B562G11	<1>
2	8	R-R	7-7	C-C	9-9	T	G					9664A83G01	<1>
2	8	R-R	7-7	C-C	9-9	T	P					9664A82G01	<1>
2	8	R-R	R-R	R-R	R-R	P	P					9688A91G01	<1>
2	8	T	5-5	6-6	7-7	5-5	T					9666A26G01	292B319G22
2	8	T	C	C	C	C	C	C	P			9671A04G01	<1>
2	8	T	C	C	C	C	C	T				9671A12G01	<1>
2	8	T	C	C	C-C	C-C	C-C	T				876A157G01	<1>
2	8	T	C-C	C-C	C-C	C-C	P					670B197G38	292B319G22
2	8	T	C-C	C-C	C-C	C-C	T					849A513G01	292B319G22
2	8	T	C-C	C-C	C-C	C-C	Y					9676A75G01	292B319G22
2	8	T	C-C-C-C	C-C	C-C	P						9666A24G01	<1>
2	8	T	C-C-C-C	C-C-C-C	P							9689A34G01	<1>

POTENTIAL	CURRENT											STYLE NO.	TEST PLUG
		A	B	C	D	E	F	G	H	I	J		
2	8	T	R-R	R-R	R-R	R-R	T					716B562G28	292B319G22
2	8	T	T	C-C	C-C	C-C	C-C					1586C42G16	<1>
2	8	T	T	C-C	C-C	C-C	C-C					774B430G28	<1>
2	8	Z	C-C	C-C	C-C	C-C	Z					9689A77G01	292B319G22
1	9	C	C	C	C	C	C	C	P			129A541G01	<1>
1	9	C	C	C	C	C	C	C	T			188A286G01	<1>
1	9	C	C	C	C-C	C-C	C-C	P				670B197G16	<1>
1	9	C-C	C-C	C-C	C	C-C	P					1586C42G40	<1>
1	9	C-C	C-C	C-C	C	C-C	T					1586C42G35	<1>
1	9	P	C-C	C	C-C	C	C-C	C				714B325G23	<1>
1	9	P	C-C-C-B	C	C-C-C-B							498A030G01	<1>
1	9	T	8-8	C-C	5-5	R-R	8					9688A48G01	<1>
0	10	5-A	5-A	5-A	5-A	5-A						9689A26G01	<1>
0	10	6-6	6-6	6-6	6-6	6-6						9664A94G01	<1>
0	10	C	C	C	C	C	C	C	C			129A529G01	<1>
0	10	C	C	C	C	C	C	C	C			774B430G17	<1>
0	10	C	C	C	C-C	C-C	C-C	C				9676A18G01	<1>
0	10	C	C	C	C-C-C-C	C	C					9688A75G01	<1>
0	10	C	C-B	C	C-B	C	C-B	C				716B562G14	<1>
0	10	C	C-C	C-C	C-C	C-C	C					716B562G13	<1>
0	10	C-A	C-A	C-A	C-A	C-A						9689A03G01	<1>
0	10	C-C	5-5	R-R	8-8	8-8						9689A11G01	<1>
0	10	C-C	C-C	C	C	C-C	C-C					714B325G26	<1>
0	10	C-C	C-C	C-C	C-C	C	C					774B430G15	<1>
0	10	C-C	C-C	C-C	C-C	C-C	C-C					498A020G01	<1>
0	10	C-C	C-C	C-C	C-C	R	R					9676A23G01	<1>
0	10	C-C	C-C	C-C	C-C-C-C							9676A20G01	<1>
0	10	C-C-C-A	C-A	C-A	C-A	C-A						9683A92G01	<1>
0	10	C-C-C-A	C-C	C-C	C-A							774B430G14	<1>
0	10	C-C-C-A	C-C-C-A	C-C								1586C42G02	<1>
0	10	C-C-C-B	C-C	C-C-C-B								498A001G01	<1>
0	10	C-C-C-C	C-C	C-C	C-C	C-C						714B325G14	<1>
0	10	C-C-C-C	C-C-C-C	C-C	C-C							774B430G23	<1>
0	10	C-D	C-D	C-D	C-D	C-D						9676A07G01	<1>
0	10	C-E	C-E	C-E	C-E	C-E						714B325G09	<1>
0	10	J	J	J	J	J	J	J	J			291B962G31	<1>
0	10	R-6-7-C	R-6-7-C	8-C								9689A43G01	<1>
0	10	R-A	R-A	R-A	R-A	R-A						9689A17G01	<1>
0	10	R-B	R-B	R-B	R-B	R-B						714B325G10	<1>
0	10	R-C	R-C	R-C	R-C	R-C						716B562G09	<1>
0	10	R-R	6-6	7-7	8-8	C-C						9688A51G01	<1>
0	10	R-R	R-R	R-R	R-R	R-R						9663A33G01	<1>

**Table 1 Notes:**

<1> When a multi-position In-Service Test Plug is not available then the individual current circuit test plug can be used.

<2> A standard FT-1 Switch with screw termination will be supplied when using the normal style number. An optional FT-1 Switch with stud and nut termination can be supplied at no additional charge provided an "S" prefix is used with FT-1 Switch style number (Example: S129A501G01).

<3> A standard FT-1 Switch with black opaque cover will be supplied when using the normal style number. An optional FT-1 Switch with clear cover can be supplied at no additional charge provided a "C" prefix is used with FT-1 Switch style number (Example: C129A501G01 or CS129A501G01 for clear cover and stud & nut termination, per note <2>).

<4> FT-1 Switch styles using the prefix "R" or "RS" can only be used with the FT-19R Assembly (refer to the FT-19R Technical Data and DB 41-078 for more details).

**Table 2 - FT-14 Switch Selection Guide**

No.	POLE ARRANGEMENT													STYLE	CODE				
	Poles	POTEN.	CURR.	A	B	C	D	E	F	G	H	I	J			K	L	M	N
14	14	0	P	P	G	Y	Z	Z	T	T	T	T	T	T	T	T	T	FT4A14T14CN4017	4017
14	14	0	P	P	P	P	P	P	P	P	P	P	P	P	P	P	P	FT4A14T14CN4001	4001
14	14	0	T	P	T	P	T	P	T	P	T	P	T	P	T	P	T	FT4A14T14CN4066	4066
14	14	0	T	T	T	T	P	P	P	P	P	P	P	P	P	P	P	FT4A14T14CN4073	4073
14	14	0	T	T	T	T	T	T	T	T	T	T	T	T	T	T	T	FT4A14T14CN4018	4018
14	14	0	T	Y	Z	T	T	Y	Y	Z	Z	P	P	P	Y	Y	Y	FT4A14T14CN4071	4071
14	8	6	C-C	C-C	C-C	C-C	P	P	P	P	P	P	P	P	P	P	P	FT4A14T08CN4067	4067
14	8	6	C-C	C-C	C-C	C-C	P	P	P	P	T	T	T	T	T	T	T	FT4A14T08CN4021	4021
14	8	6	C-C	C-C	C-C	C-C	T	T	T	T	P	P	P	P	P	P	P	FT4A14T08CN4022	4022
14	8	6	C-C	C-C	C-C	C-C	T	T	T	T	T	T	T	T	T	T	T	FT4A14T08CN4023	4023
14	8	6	C-C	C-C	C-C	C-C	T	T	T	T	Y	Y	Y	Y	Y	Y	Y	FT4A14T08CN4024	4024
14	8	6	C-C	C-C	C-C	C-C	T	T	Y	Y	Y	Y	Y	Y	Y	Y	Y	FT4A14T08CN4025	4025
14	8	6	C-C	C-C	C-C	C-C	Z	Z	Z	Z	Y	Y	Y	Y	Y	Y	Y	FT4A14T08CN4026	4026
14	8	6	C-C	C-C	C-C	C-C	Z	Z	Z	Z	T	T	Y	Y	Y	Y	Y	FT4A14T08CN4027	4027
14	8	6	P	P	P	C-C	C-C	C-C	C-C	P	P	P	P	P	P	P	P	FT4A14T08CN4003	4003
14	8	6	P	P	P	C-C	C-C	C-C	C-C	P	T	P	P	P	P	P	P	FT4A14T08CN4028	4028
14	8	6	T	T	T	C-C	C-C	C-C	C-C	T	T	T	T	T	T	T	T	FT4A14T08CN4030	4030
14	8	6	T	T	T	C-C	C-C	C-C	C-C	W	G	O	Y	Z	Z	Z	Z	FT4A14T08CN4031	4031
14	8	6	T	T	T	T	C-C	C-C	C-C	T	T	T	T	T	T	T	T	FT4A14T08CN4032	4032
14	8	6	T	Y	Z	R-R	6-6	7-7	P	P	P	Y	Y	Y	Y	Y	Y	FT4A14T08CN4072	4072
14	7	7	P	P	P	P	P	P	P	C-C	C-C	C-C	C	C	C	C	C	FT4A14T07CN4033	4033
14	7	7	P	P	T	T	P	P	P	C-C	C-C	C-C	C	C	C	C	C	FT4A14T07CN4034	4034
14	6	8	C-C	C-C	C-C	C-C	C-C	P	P	P	P	P	P	P	P	P	P	FT4A14T04CN4068	4068

Table 2 - FT-14 Switch Selection Guide (continued)

No. Poles	POLE ARRANGEMENT													STYLE	CODE			
	POTEN.	CURR.	A	B	C	D	E	F	G	H	I	J	K			L	M	N
14	6	8	C-C	C-C	C-C	C-C	P	P	P	P	T	T					FT4A14T06CN4035	4035
14	6	8	C-C	C-C	C-C	C-C	T	T	P	P	P	P					FT4A14T06CN4036	4036
14	6	8	C-C	C-C	C-C	C-C	T	T	T	T	T	T					FT4A14T06CN4037	4037
14	6	8	C-C	C-C	C-C	C-C	T	Y	Y	Y	Y	Y					FT4A14T06CN4038	4038
14	6	8	C-C	C-C	C-C	C-C	Z	O	Y	G	P	T					FT4AT1406CN4064	4064
14	6	8	C-C	C-C	C-C	C-C	Z	Z	Z	Y	Y	Y					FT4A14T06CN4040	4040
14	6	8	P	C-C	C-C	C-C	C-C	P	P	P	P	P					FT4A14T06CN4002	4002
14	6	8	P	P	O	O	O	R-R	6-6	7-7	8-8						FT4A14T06CN4043	4043
14	6	8	P	P	P	C-C	C-C	C-C	C-C	P	P	P					FT4A14T06CN4044	4044
14	6	8	P	P	P	P	C-C	C-C	C-C	C-C	P	P					FT4A14T06CN4065	4065
14	6	8	P	P	P	P	C-C	C-C	C-C	C-C	T	T					FT4A14T06CN4045	4045
14	6	8	P	P	P	P	P	P	C-C	C-C	C-C	C-C					FT4A14T06CN4046	4046
14	6	8	T	C-C	T	C-C	T	C-C	T	C-C	T	C-C	T	T			FT4A14T06CN4048	4048
14	6	8	T	T	T	C-C	C-C	C-C	8-8	W	P	P					FT4A14T06CN4049	4049
14	6	8	T	T	T	C-C	C-C	C-C	C-C	T	T	T					FT4A14T06CN4050	4050
14	6	8	T	T	T	C-C	C-C	C-C	T	C-C	T	T					FT4A14T06CN4051	4051
14	6	8	T	T	T	T	C-C	C-C	C-C	C-C	T	T					FT4A14T06CN4052	4052
14	6	8	T	T	T	T	T	T	C-C	C-C	C-C	C-C					FT4A14T06CN4053	4053
14	6	8	T	T	T	T	Z	Z	C-C	C-C	C-C	C-C					FT4A14T06CN4054	4054
14	6	8	T	T	T	Z	Z	Z	C-C	C-C	C-C	C-C					FT4A14T06CN4055	4055
14	6	8	Z	Z	Z	Z	C-C	C-C	C-C	C-C	T	T					FT4A14T06CN4074	4074
14	6	8	Z	Z	Z	Z	Z	Z	C-C	C-C	C-C	C-C					FT4A14T06CN4056	4056
14	5	9	T	P	P	P	P	C-C	C-C	C-C	C-C	C					FT4A14T05CN4057	4057
14	4	10	9-9	9-9	9-9	9-9	Z	Z	Z	9-9	9-9	Z					FT4A14T04CN4058	4058
14	4	10	P	P	C-C	C-C	C-C	C-C	C-C	C-C	P	P					FT4A14T04CN4059	4059
14	2	12	9-9	9-9	9-9	9-9	Z	9-9	9-9	Z							FT4A14T02CN4060	4060
14	2	12	C-C	C-C	C-C	C-C	C-C	C-C	C-C	P	P						FT4A14T02CN4069	4069
14	2	12	C-C	C-C	C-C	C-C	C-C	C-C	C-C	T	T						FT4A14T02CN4061	4061
14	2	12	P	C-C	C-C	C-C	C-C	C-C	C-C	C-C	P						FT4A14T02CN4075	4075
14	2	12	T	T	C-C	C-C	C-C	C-C	C-C	C-C	C-C						FT4A14T02CN4062	4062
14	0	14	C-C	C-C	C-C	C-C	C-C	C-C	C-C	C-C	C-C						FT4A14T00CN4063	4063
14	0	14	C-C	C-C	C-C	C-C	C-C	C-C	C-C	C-C	C-C						FT4A14T00CN4070	4070
13	13	0	T	T	T	T	T	T	T	T	T	T	T	T	.		FT4A13T13CN4015	4015
12	12	0	P	P	P	P	P	P	P	P	P	P	P	P	.		FT4A12T12CN4007	4007
12	12	0	T	T	T	T	T	T	T	T	T	T	T	T	.		FT4A12T12CN4008	4008
12	4	8	C-C	C-C	C-C	C-C	T	T	P	P	.	.					FT4A12T04CN4011	4011
12	4	8	C-C	C-C	C-C	C-C	Z	Z	Z	Z	.	.					FT4A12T04CN4012	4012
12	4	8	T	T	T	W	.	.	C-C	C-C	C-C	C-C					FT4A12T04CN4013	4013
12	4	8	.	C-C	C-C	C-C	C-C	T	T	T	T	.					FT4A12T04CN4010	4010
12	0	12	C-C	C-C	C-C	C-C	C-C	C-C	C-C	.	.						FT4A12T00CN4014	4014
11	11	0	T	T	T	T	T	T	T	T	T	T	T	.	.	.	FT4A11T11CN4004	4004
11	3	8	C-C	C-C	C-C	C-C	Z	Z	Z	.	.	.					FT4A11T03CN4006	4006

Table 3 - FT-1 Switch Selection by Style

POTENTIAL	CURRENT	STYLE NO.
10	0	129A501G01
8	0	129A502G01
7	0	129A503G01
6	0	129A504G01
5	0	129A505G01
4	0	129A506G01
2	2	129A507G01
3	2	129A508G01
4	2	129A509G01
5	2	129A510G01
3	4	129A511G01
4	4	129A512G01
6	4	129A513G01
4	6	129A514G01
3	6	129A515G01
0	6	129A516G01
0	8	129A517G01
2	8	129A518G01
2	8	129A519G01
6	4	129A520G01
2	6	129A521G01
0	6	129A523G01
4	0	129A524G01
2	6	129A525G01
7	0	129A526G01
4	6	129A528G01
0	10	129A529G01
4	4	129A530G01
0	2	129A531G01
6	4	129A532G01
3	2	129A533G01
2	0	129A534G01
3	7	129A535G01
8	0	129A536G01
2	4	129A537G01
4	0	129A538G01
10	0	129A539G01
1	6	129A540G01
1	9	129A541G01
8	2	129A542G01
3	3	129A543G01
4	4	129A544G01
5	4	129A545G01
8	0	129A546G01
7	0	129A547G01
9	0	129A548G01

POTENTIAL	CURRENT	STYLE NO.
8	0	129A549G01
6	0	129A550G01
9	0	129A551G01
6	3	129A552G01
7	3	129A553G01
0	5	129A555G01
3	3	1485B70G09
3	6	1485B70G10
3	6	1485B70G11
4	0	1586C39G01
4	0	1586C39G02
6	0	1586C40G01
0	8	1586C41G01
0	10	1586C42G02
4	6	1586C42G03
4	6	1586C42G05
10	0	1586C42G06
2	8	1586C42G08
2	8	1586C42G09
4	6	1586C42G10
6	4	1586C42G11
6	4	1586C42G12
6	4	1586C42G13
6	4	1586C42G14
10	0	1586C42G15
2	8	1586C42G16
3	7	1586C42G17
4	6	1586C42G18
3	7	1586C42G19
8	2	1586C42G20
4	6	1586C42G21
6	4	1586C42G22
10	0	1586C42G23
10	0	1586C42G24
10	0	1586C42G25
8	2	1586C42G26
6	4	1586C42G27
10	0	1586C42G28
10	0	1586C42G29
10	0	1586C42G30
10	0	1586C42G31
8	2	1586C42G32
8	2	1586C42G33
4	6	1586C42G34
1	9	1586C42G35
4	6	1586C42G36

POTENTIAL	CURRENT	STYLE NO.
4	6	1586C42G37
8	2	1586C42G38
9	1	1586C42G39
1	9	1586C42G40
10	0	1586C42G41
2	8	1586C42G42
3	7	1586C42G43
10	0	1586C42G44
10	0	1586C42G45
10	0	1586C42G46
8	2	1586C42G47
4	6	1586C42G48
0	8	188A229G01
5	2	188A261G01
1	9	188A286G01
0	6	188A304G01
6	0	188A416G01
0	6	188A454G01
4	3	188A477G01
4	6	188A523G01
3	4	188A618G01
5	2	188A622G01
6	2	188A632G01
5	4	188A633G01
0	2	291B954G12
2	0	291B954G13
2	0	291B954G14
2	0	291B954G15
2	0	291B954G16
0	4	291B956G13
2	2	291B956G18
0	4	291B956G23
4	0	291B956G24
4	0	291B956G25
3	1	291B956G26
0	4	291B956G27
1	3	291B956G28
0	4	291B956G29
2	2	291B956G30
4	0	291B956G31
4	0	291B956G32
3	2	291B957G09
5	0	291B957G15
3	2	291B957G16
3	2	291B957G17
3	3	291B958G24

POTENTIAL	CURRENT	STYLE NO.
6	0	291B958G25
0	6	291B958G26
2	4	291B958G27
0	6	291B958G28
0	6	291B958G29
2	4	291B958G30
2	4	291B958G31
6	0	291B958G33
5	2	291B959G18
7	0	291B959G19
3	4	291B959G20
3	4	291B959G26
5	2	291B959G27
7	0	291B959G28
0	7	291B959G29
7	0	291B959G30
3	4	291B959G32
7	0	291B959G33
0	8	291B960G20
6	2	291B960G26
3	5	291B960G27
0	8	291B960G33
6	2	291B960G36
8	0	291B960G37
2	6	291B960G38
8	0	291B960G39
5	4	291B961G22
6	3	291B961G23
4	6	291B961G25
2	7	291B961G26
3	6	291B961G27
5	4	291B961G28
3	6	291B961G29
6	3	291B961G30
0	10	291B962G31
0	10	498A001G01
1	4	498A002G01
1	6	498A003G01
0	8	498A004G01
3	4	498A008G01
1	8	498A009G01
4	6	498A010G01
9	1	498A011G01
4	0	498A012G01
7	0	498A013G01
0	6	498A014G01

Table 3 - FT-1 Switch Selection by Style (continued)

POTENTIAL	CURRENT	STYLE NO.	POTENTIAL	CURRENT	STYLE NO.	POTENTIAL	CURRENT	STYLE NO.	POTENTIAL	CURRENT	STYLE NO.
6	4	498A015G01	2	8	714B325G12	0	3	716B871G10	2	8	876A157G01
4	4	498A016G01	2	8	714B325G13	3	0	716B871G11	6	4	877A077G01
0	6	498A017G01	0	10	714B325G14	3	0	716B871G12	10	0	9641A64G01
1	7	498A018G01	2	8	714B325G15	8	0	719B591G09	2	8	9642A36G01
1	7	498A019G01	6	4	714B325G16	8	0	719B591G10	10	0	9646A77G01
0	10	498A020G01	4	6	714B325G17	4	4	719B591G11	8	2	9647A11G01
0	9	498A021G01	6	4	714B325G18	8	0	719B591G12	8	2	9647A12G01
4	0	498A022G01	4	6	714B325G19	4	4	719B591G13	4	0	9647A17G01
0	9	498A023G01	4	6	714B325G20	8	0	719B591G14	2	8	9647A18G01
3	6	498A024G01	2	8	714B325G21	0	4	763A109G01	9	1	9647A19G01
0	8	498A025G01	3	7	714B325G22	4	0	763A166G01	4	6	9647A20G01
0	2	498A026G01	1	9	714B325G23	6	2	763A167G01	10	0	9647A21G01
0	4	498A027G01	4	6	714B325G24	7	0	763A168G01	10	0	9647A22G01
4	5	498A028G01	3	7	714B325G25	4	6	774B430G09	4	6	9647A23G01
0	8	498A029G01	0	10	714B325G26	4	6	774B430G10	8	2	9647A98G01
1	9	498A030G01	6	4	714B325G27	2	8	774B430G11	10	0	9649A37G01
2	8	498A031G01	6	4	714B325G28	2	8	774B430G12	0	8	9660A84G01
2	8	498A032G01	6	4	714B325G29	4	6	774B430G13	4	6	9660A85G01
4	4	629A315G01	8	2	714B325G30	0	10	774B430G14	6	4	9660A91G01
6	3	629A483G01	8	2	714B325G31	0	10	774B430G15	10	0	9660A92G01
6	0	629A568G01	4	6	714B325G32	3	6	774B430G16	4	6	9660A96G01
6	4	629A735G01	0	10	716B562G09	0	10	774B430G17	0	6	9660A97G01
1	9	670B197G16	10	0	716B562G10	4	6	774B430G18	10	0	9663A25G01
8	2	670B197G17	2	8	716B562G11	10	0	774B430G19	6	4	9663A31G01
4	6	670B197G18	3	7	716B562G12	4	6	774B430G20	0	10	9663A33G01
6	4	670B197G19	0	10	716B562G13	4	6	774B430G21	3	6	9663A34G01
5	5	670B197G20	0	10	716B562G14	2	8	774B430G22	10	0	9663A41G01
10	0	670B197G21	6	4	716B562G15	0	10	774B430G23	3	7	9663A59G01
3	7	670B197G22	4	6	716B562G16	4	6	774B430G24	8	2	9663A60G01
4	6	670B197G23	6	4	716B562G17	2	8	774B430G28	3	6	9663A74G01
10	0	670B197G24	4	6	716B562G18	1	0	774B542G09	1	6	9663A77G01
6	4	670B197G25	6	4	716B562G19	6	4	836A867G01	1	2	9663A78G01
10	0	670B197G26	6	4	716B562G20	0	4	837A087G01	7	0	9663A79G01
4	6	670B197G27	8	2	716B562G21	0	8	837A098G01	4	0	9663A80G01
6	4	670B197G28	2	8	716B562G24	0	8	837A099G01	10	0	9664A78G01
10	0	670B197G31	2	8	716B562G25	2	8	837A101G01	10	0	9664A79G01
4	6	670B197G32	8	2	716B562G26	2	8	837A407G01	4	6	9664A80G01
8	2	670B197G33	2	8	716B562G27	2	8	837A616G01	4	6	9664A81G01
6	4	670B197G34	2	8	716B562G28	2	8	837A664G01	2	8	9664A82G01
3	7	670B197G35	3	6	716B562G30	8	2	837A665G01	2	8	9664A83G01
10	0	670B197G36	8	2	716B562G35	6	0	837A889G01	10	0	9664A84G01
6	4	670B197G37	6	4	716B562G36	6	4	849A307G01	4	6	9664A85G01
2	8	670B197G38	4	6	716B562G37	2	8	849A513G01	4	6	9664A86G01
0	10	714B325G09	2	8	716B562G38	3	6	861A551G01	4	6	9664A87G01
0	10	714B325G10	2	8	716B562G39	6	4	861A670G01	10	0	9664A88G01
3	7	714B325G11	3	0	716B871G09	4	0	862A584G01	4	6	9664A89G01

Table 3 - FT-1 Switch Selection by Style (continued)

POTENTIAL	CURRENT	STYLE NO.
10	0	9664A92G01
4	6	9664A93G01
0	10	9664A94G01
10	0	9664A97G01
10	0	9664A98G01
0	4	9666A12G01
10	0	9666A13G01
4	6	9666A20G01
4	6	9666A21G01
2	8	9666A23G01
2	8	9666A24G01
2	8	9666A26G01
6	4	9666A27G01
8	2	9666A28G01
8	2	9666A34G01
2	8	9666A35G01
10	0	9666A36G01
6	4	9666A37G01
4	6	9666A38G01
6	0	9666A39G01
4	2	9667A02G01
10	0	9667A03G01
10	0	9667A06G01
5	2	9667A17G01
2	6	9667A21G01
4	6	9667A22G01
2	8	9667A68G01
4	6	9667A69G01
10	0	9667A78G01
4	6	9667A80G01
10	0	9667A86G01
10	0	9667A93G01
10	0	9668A27G01
10	0	9668A54G01
2	6	9668A69G01
1	8	9668A70G01
4	6	9670A05G01
10	0	9670A34G01
10	0	9670A35G01
10	0	9670A97G01
10	0	9670A98G01
2	8	9671A04G01
2	2	9671A05G01
2	8	9671A12G01
10	0	9671A13G01
2	8	9671A22G01

POTENTIAL	CURRENT	STYLE NO.
3	7	9671A26G01
10	0	9671A68G01
10	0	9671A69G01
4	6	9671A70G01
4	6	9671A93G01
10	0	9671A94G01
10	0	9671A95G01
4	6	9672A01G01
10	0	9672A02G01
4	2	9672A03G01
0	8	9672A10G01
2	8	9672A23G01
10	0	9672A71G01
0	6	9672A72G01
4	0	9672A73G01
10	0	9672A74G01
10	0	9672A75G01
10	0	9672A77G01
6	4	9672A80G01
8	2	9672A83G01
3	7	9672A86G01
6	4	9672A87G01
2	8	9672A88G01
8	2	9672A89G01
4	6	9672A90G01
2	8	9672A94G01
2	8	9672A95G01
10	0	9672A97G01
10	0	9672A98G01
6	4	9672A99G01
2	8	9676A01G01
8	2	9676A04G01
6	4	9676A05G01
6	4	9676A06G01
0	10	9676A07G01
10	0	9676A08G01
6	4	9676A09G01
4	6	9676A10G01
2	8	9676A11G01
10	0	9676A14G01
8	2	9676A15G01
4	6	9676A17G01
0	10	9676A18G01
3	3	9676A19G01
0	10	9676A20G01
0	10	9676A23G01

POTENTIAL	CURRENT	STYLE NO.
0	7	9676A24G01
0	9	9676A25G01
4	0	9676A26G01
4	0	9676A27G01
10	0	9676A34G01
4	6	9676A35G01
2	2	9676A36G01
5	0	9676A37G01
2	0	9676A38G01
10	0	9676A53G01
4	6	9676A55G01
4	6	9676A58G01
4	6	9676A60G01
6	0	9676A65G01
4	6	9676A68G01
6	4	9676A71G01
10	0	9676A72G01
10	0	9676A73G01
10	0	9676A74G01
2	8	9676A75G01
3	7	9676A76G01
3	4	9676A79G01
4	6	9676A80G01
10	0	9676A81G01
2	7	9676A83G01
10	0	9676A84G01
8	2	9676A86G01
10	0	9676A87G01
10	0	9676A88G01
10	0	9676A89G01
10	0	9676A90G01
10	0	9676A91G01
10	0	9676A93G01
10	0	9676A94G01
4	6	9676A95G01
2	8	9676A96G01
10	0	9676A97G01
4	6	9676A98G01
4	6	9676A99G01
10	0	9683A01G01
10	0	9683A02G01
10	0	9683A03G01
4	6	9683A04G01
4	6	9683A05G01
10	0	9683A06G01
4	6	9683A07G01

POTENTIAL	CURRENT	STYLE NO.
8	0	9683A10G01
4	6	9683A15G01
2	8	9683A16G01
10	0	9683A17G01
10	0	9683A18G01
10	0	9683A19G01
4	6	9683A20G01
4	6	9683A21G01
2	6	9683A22G01
10	0	9683A61G01
10	0	9683A69G01
10	0	9683A70G01
6	2	9683A71G01
8	2	9683A72G01
4	6	9683A73G01
10	0	9683A75G01
0	6	9683A76G01
8	0	9683A80G01
6	0	9683A81G01
2	8	9683A87G01
10	0	9683A88G01
2	8	9683A89G01
0	10	9683A92G01
0	8	9683A93G01
6	4	9683A94G01
10	0	9683A95G01
3	7	9683A96G01
10	0	9683A97G01
4	6	9683A98G01
2	8	9683A99G01
4	6	9688A01G01
4	8	9688A02G01
2	2	9688A03G01
6	0	9688A04G01
8	2	9688A07G01
10	0	9688A08G01
10	0	9688A09G01
10	0	9688A10G01
4	6	9688A11G01
10	0	9688A12G01
10	0	9688A13G01
10	0	9688A14G01
10	0	9688A15G01
10	0	9688A16G01
10	0	9688A17G01
10	0	9688A18G01

Table 3 - FT-1 Switch Selection by Style (continued)

POTENTIAL	CURRENT	STYLE NO.
10	0	9688A19G01
10	0	9688A20G01
4	6	9688A22G01
10	0	9688A23G01
10	0	9688A24G01
2	2	9688A25G01
10	0	9688A26G01
10	0	9688A28G01
0	6	9688A30G01
4	6	9688A38G01
6	0	9688A40G01
4	6	9688A41G01
0	8	9688A42G01
0	6	9688A43G01
10	0	9688A44G01
9	0	9688A45G01
2	0	9688A46G01
1	9	9688A48G01
3	7	9688A50G01
0	10	9688A51G01
10	0	9688A52G01
10	0	9688A53G01
10	0	9688A54G01
5	0	9688A55G01
10	0	9688A56G01
10	0	9688A57G01
10	0	9688A58G01
10	0	9688A59G01
8	2	9688A62G01
3	0	9688A63G01
4	0	9688A64G01
2	6	9688A65G01
10	0	9688A66G01
3	1	9688A67G01
0	8	9688A70G01
10	0	9688A71G01
10	0	9688A72G01
10	0	9688A73G01
10	0	9688A74G01
0	10	9688A75G01
10	0	9688A76G01
10	0	9688A77G01
10	0	9688A78G01
4	0	9688A79G01
10	0	9688A80G01
10	0	9688A81G01

POTENTIAL	CURRENT	STYLE NO.
10	0	9688A82G01
3	4	9688A83G01
10	0	9688A84G01
2	8	9688A85G01
3	7	9688A86G01
4	6	9688A87G01
10	0	9688A88G01
10	0	9688A89G01
10	0	9688A90G01
2	8	9688A91G01
10	0	9688A92G01
10	0	9688A93G01
2	8	9688A94G01
10	0	9688A95G01
10	0	9688A96G01
8	2	9688A98G01
7	0	9688A99G01
6	4	9689A01G01
2	8	9689A02G01
0	10	9689A03G01
4	6	9689A04G01
4	6	9689A06G01
4	6	9689A07G01
10	0	9689A08G01
10	0	9689A09G01
4	5	9689A10G01
0	10	9689A11G01
0	4	9689A12G01
10	0	9689A13G01
4	6	9689A14G01
10	0	9689A15G01
6	2	9689A16G01
0	10	9689A17G01
6	4	9689A18G01
4	6	9689A19G01
0	8	9689A20G01
9	0	9689A21G01
8	0	9689A22G01
0	6	9689A23G01
8	2	9689A25G01
0	10	9689A26G01
0	8	9689A27G01
4	6	9689A28G01
4	6	9689A29G01
10	0	9689A31G01
10	0	9689A32G01

POTENTIAL	CURRENT	STYLE NO.
4	6	9689A33G01
2	8	9689A34G01
10	0	9689A36G01
10	0	9689A37G01
6	4	9689A38G01
10	0	9689A40G01
4	6	9689A41G01
6	4	9689A42G01
0	10	9689A43G01
3	7	9689A45G01
10	0	9689A47G01
10	0	9689A49G01
10	0	9689A50G01
4	6	9689A53G01
1	4	9689A54G01
3	6	9689A56G01
3	6	9689A57G01
10	0	9689A59G01
10	0	9689A60G01
10	0	9689A61G01
10	0	9689A62G01
10	0	9689A63G01
10	0	9689A65G01
10	0	9689A69G01
10	0	9689A70G01
8	2	9689A72G01
6	4	9689A73G01
0	2	9689A74G01
3	0	9689A75G01
8	0	9689A76G01
2	8	9689A77G01
0	6	9689A78G01
10	0	9689A79G01
4	0	9689A80G01
6	4	9689A81G01
4	6	9689A84G01
4	6	9689A85G01
8	2	9689A87G01
10	0	9689A88G01
4	6	9689A89G01
8	0	9689A90G01
10	0	9689A91G01
8	0	9689A95G01
10	0	9689A97G01
10	0	9689A99G01

TYPICAL FT-1 SWITCH CONNECTION SCHEMATIC

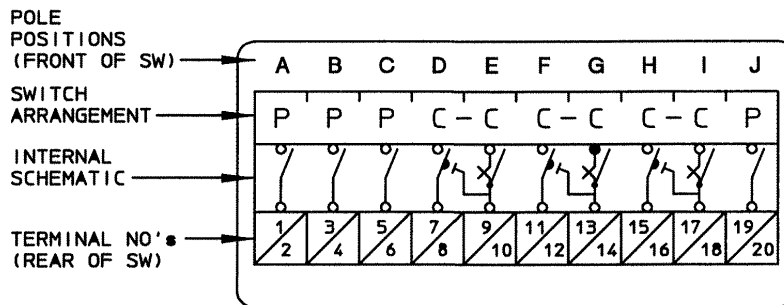
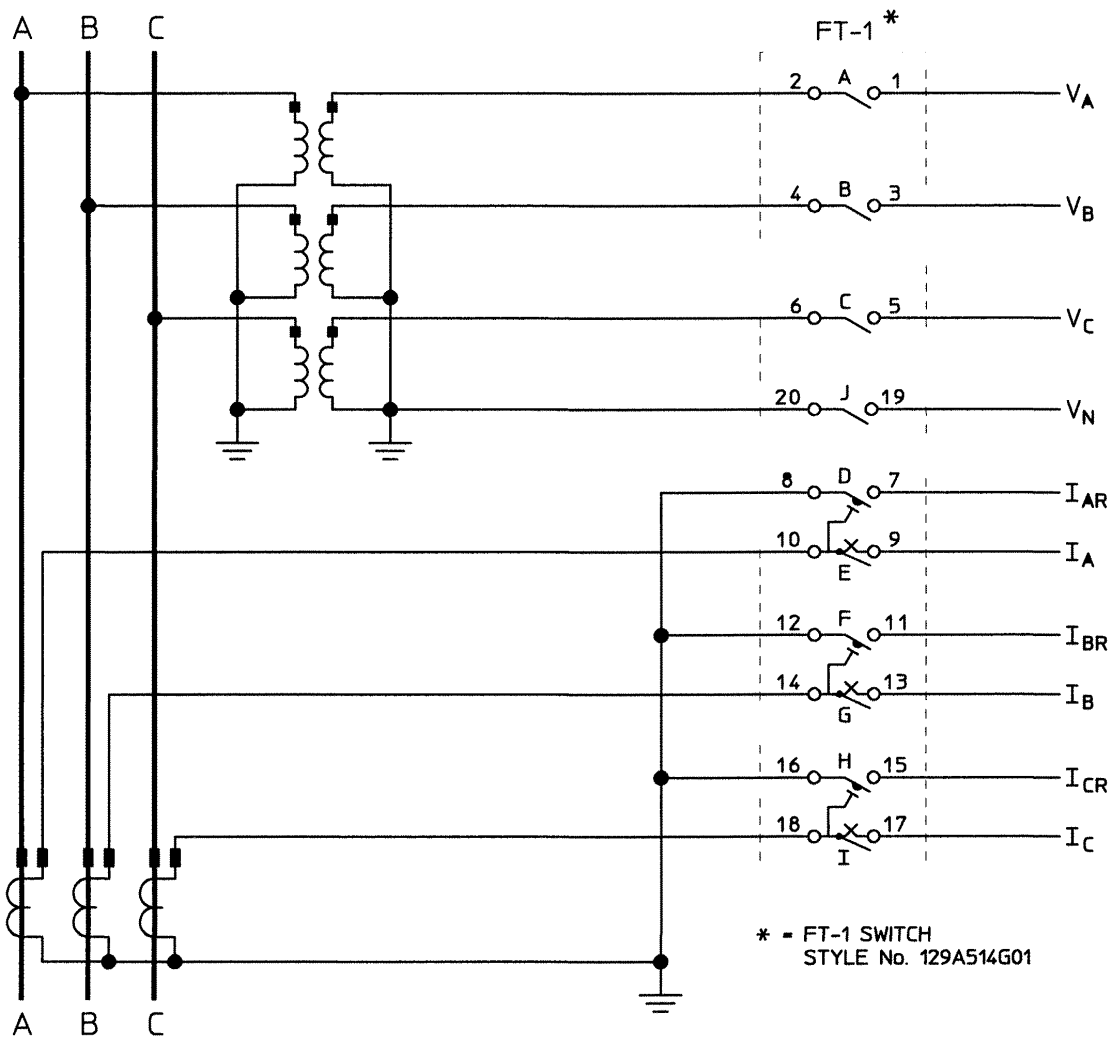

FT-1 STYLE No. 129A514G01  
(SWITCH LAYOUT)

Rev. 2  
9666A11

Figure 11. Typical FT-1 Switch Connection Schematic

FT-1

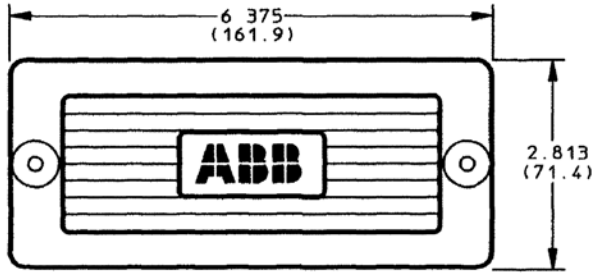

FIG. 1 FT-1 WITH BLACK COVER

OUTLINE

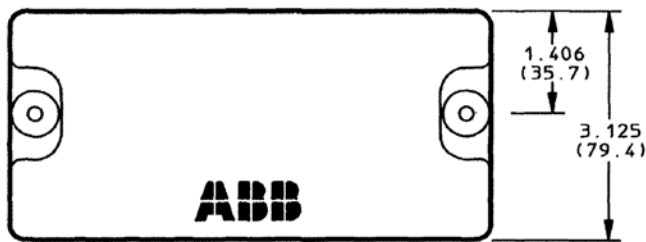
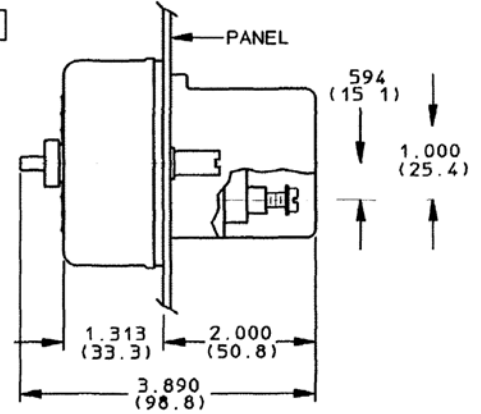
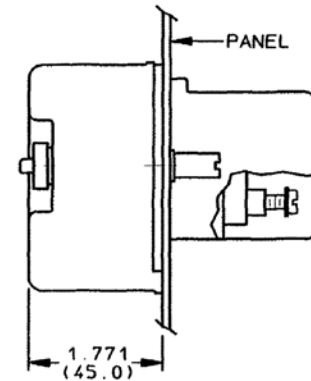
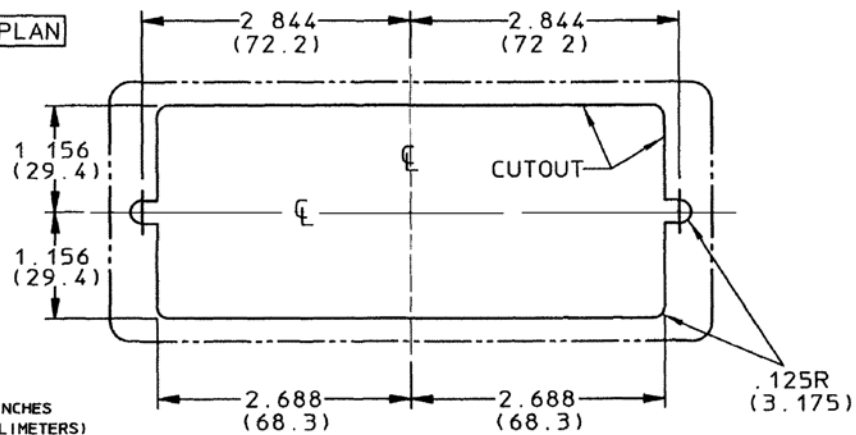

FIG. 2 FT-1 WITH CLEAR COVER

(OTHERWISE SAME AS FIG. 1)



DRILLING PLAN



DIMENSIONS IN INCHES  
(DIMENSIONS IN MILLIMETERS)

Rev. 7  
129A500

Figure 12. FT-1 Switch Outline and Drilling Plan

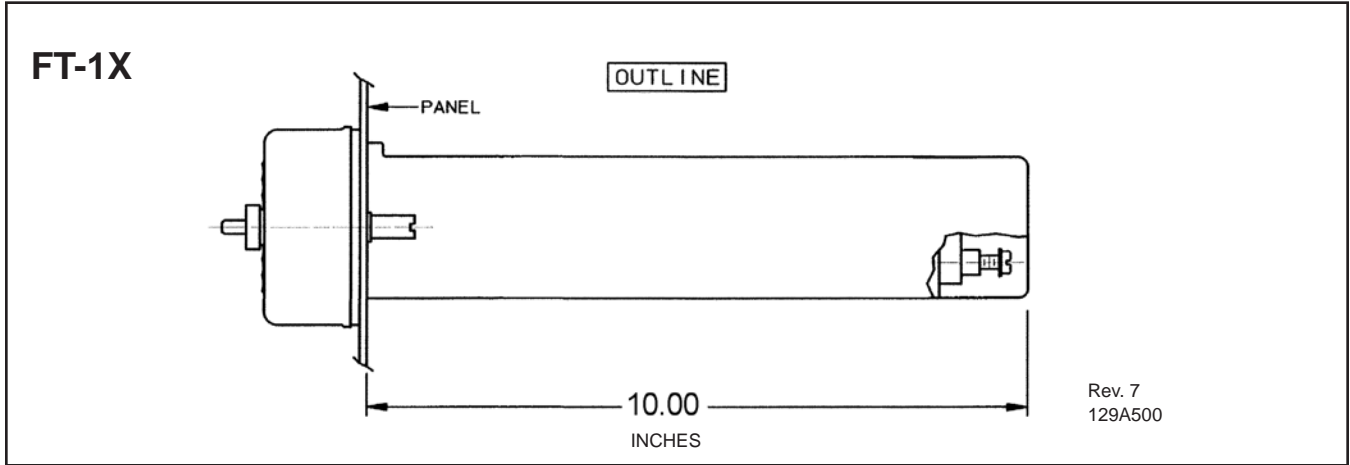

Figure 13. FT-1X (extended length) Outline and Drilling Plan (otherwise same as FT-1, Fig. 12)

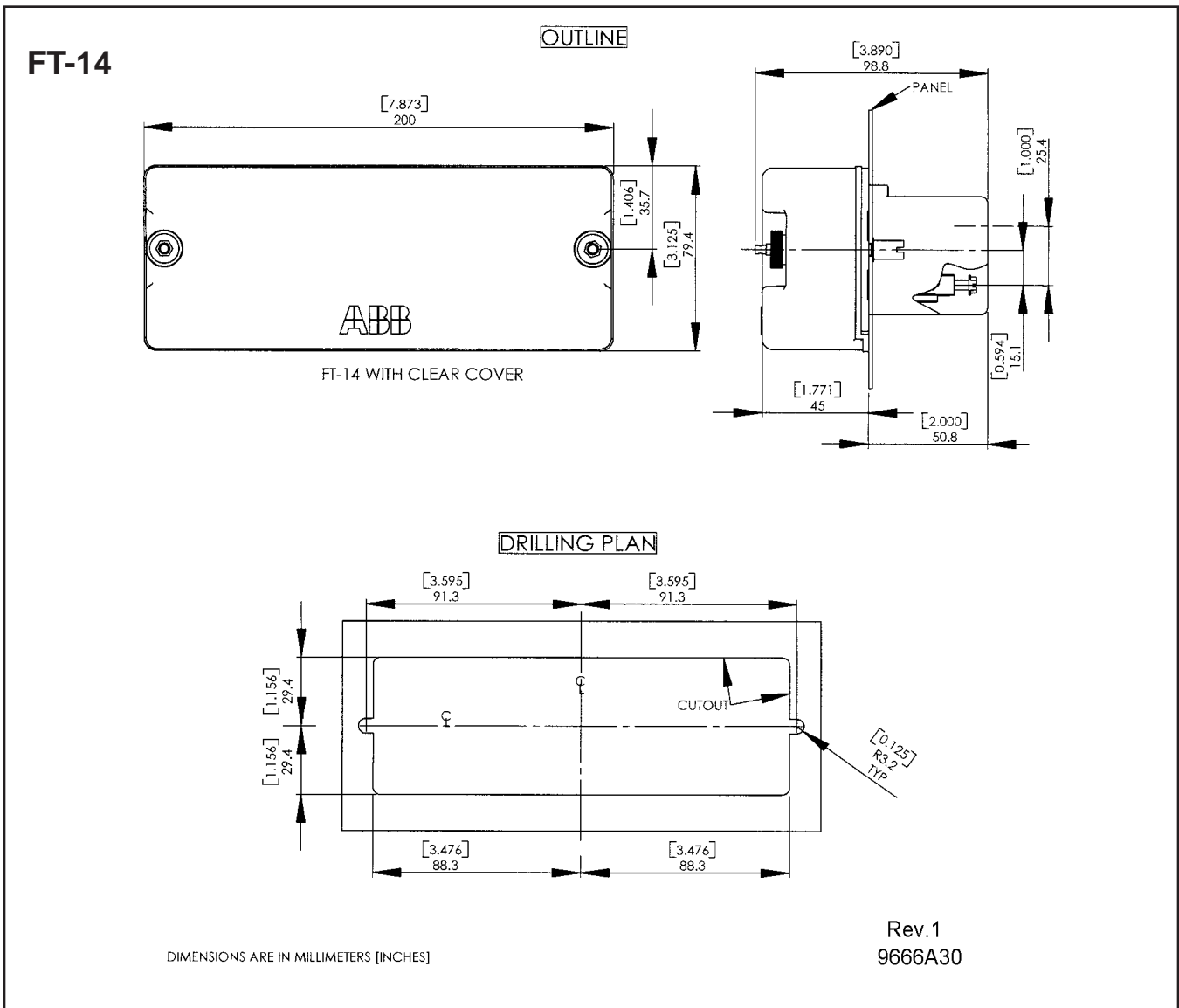

Figure 14. FT-14 Switch Outline and Drilling Plan

**FT-1F**

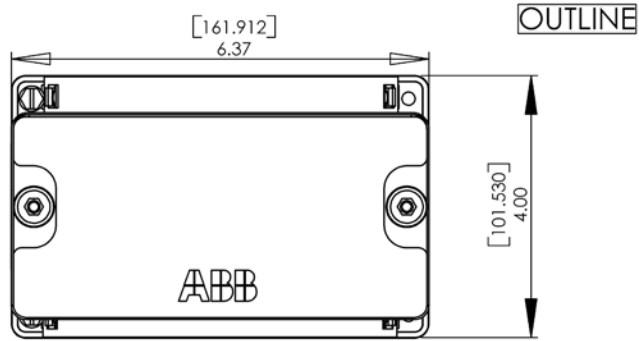

FIG 1. FT-1F WITH CLEAR COVER

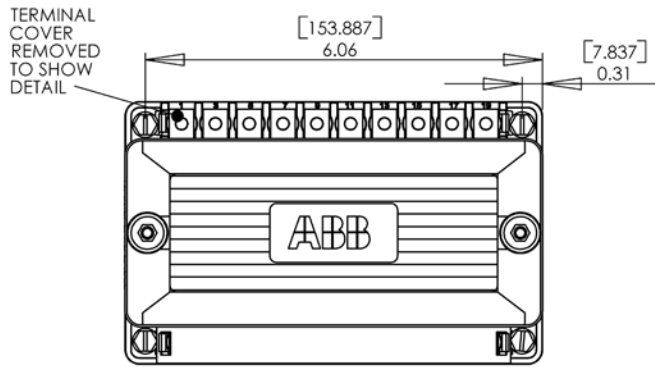
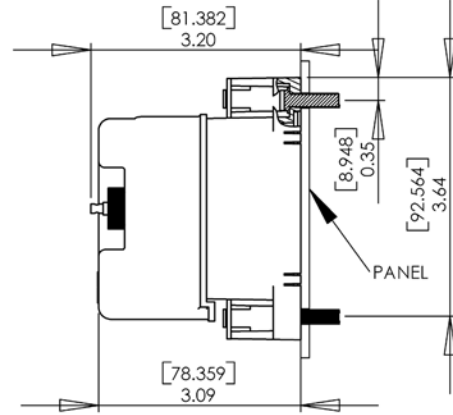
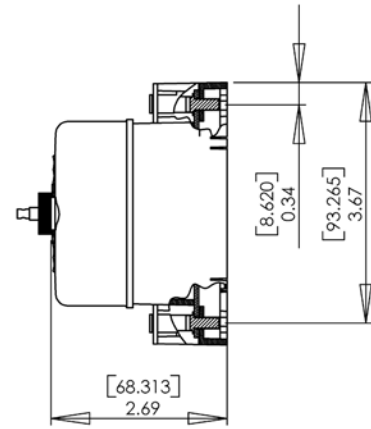

FIG 2. FT-1F WITH BLACK COVER



**DRILLING PLAN**

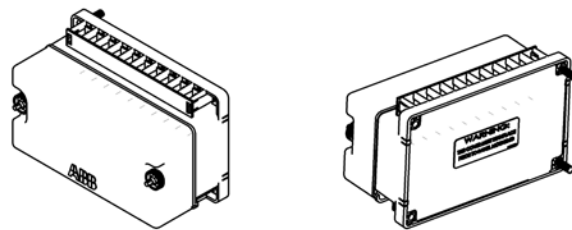
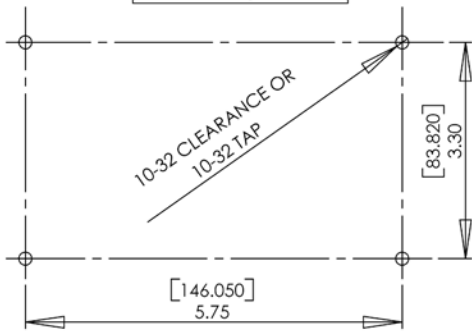

FIG 3. ISOMETRIC VIEWS  
FT-1F WITH CLEAR COVER

Rev. 1  
9666A18

DIMENSIONS ARE IN INCHES [MILLIMETERS]+

Figure 15. FT-1F Switch Outline and Drilling Plan

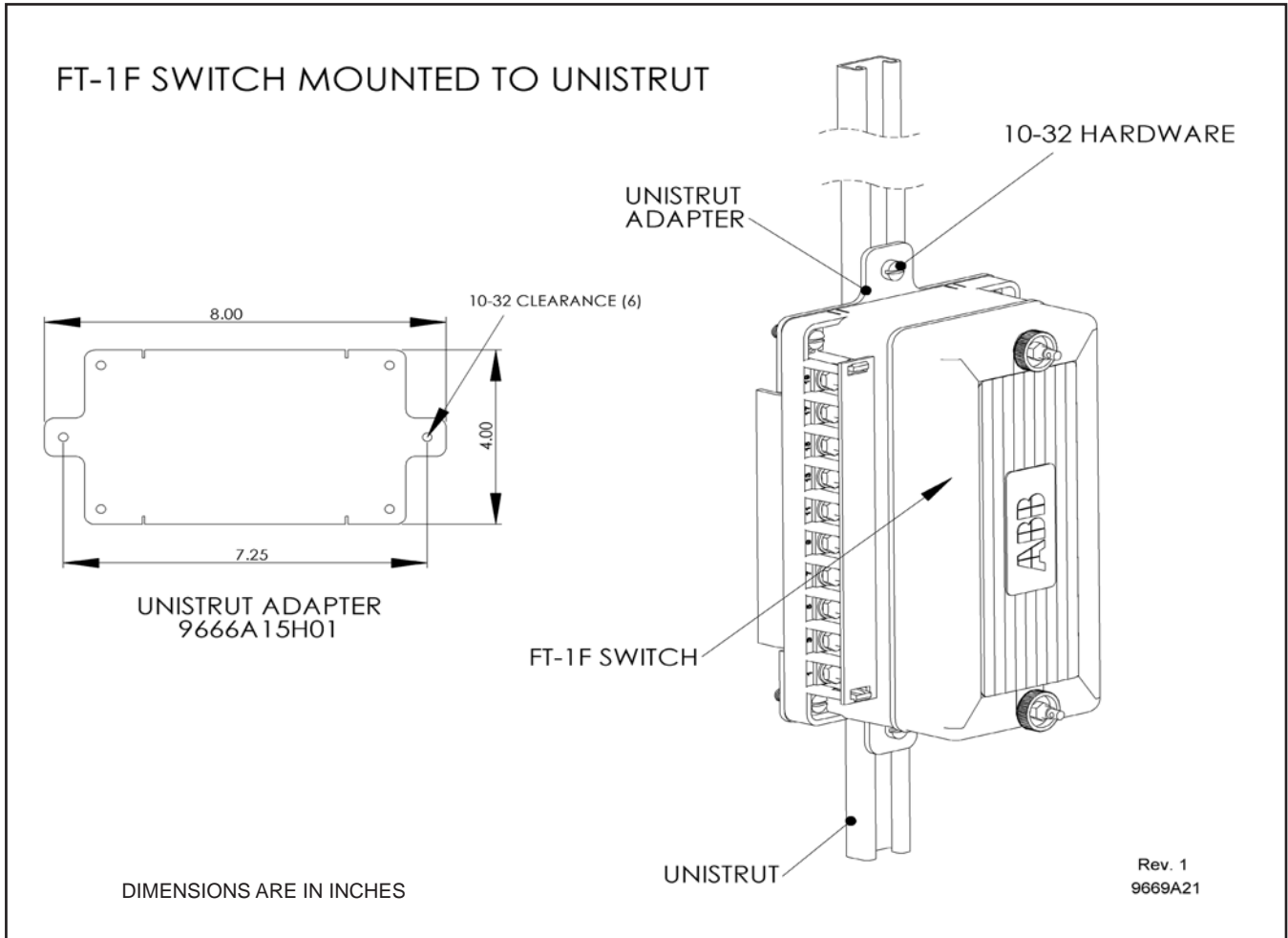

Figure 16. Railmount View of FT-1F using Unistrut Adapter

**Reference**

- For a breakdown of FT-1 Current and Potential poles by Style Number see Table 3, pages 23 to 26.
- A Typical FT-1 Switch Connection Schematic is given in Figure 11, page 27.
- Refer to pages 6 and 7 for FT-1, FT-1F, FT-1X and FT-14 Style Number examples, options, and ordering information.
- For rack mounted assemblies of FT-1 Switches, see Descriptive Bulletin 41-078, FT-19R and FT-19RX Flexitest Switch Assemblies.

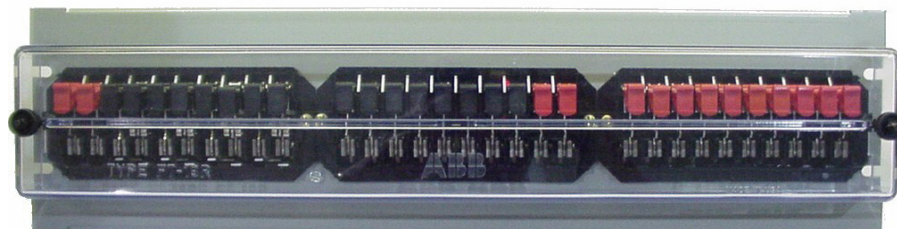

Figure 17. Typical FT-19R assembly (19" panel accommodates up to 3 FT-1 switches)



ABB Inc.  
4300 Coral Ridge Drive  
Coral springs, Florida 33065  
Telephone: +1 954-752-6700  
Fax: +1 954-345-5329  
[www.abb.com/substationautomation](http://www.abb.com/substationautomation)